

Plant Tonasa
Line Tonasa V
Project .. Tonasa V, 09-45231 v.1.0

Generated .. 1/19/2012 8:52:53 AM
Revision Customer A1
Initials..... CML

Table of Contents

Chapter

Interconnection Diagrams 01

520LG01A03

	Address	Position:	Term:
220 VAC		X06.08.A	01L
Bypass Operation	101UP110A01C82	DI N02.01..08.22	X06.08.A 01
Mains Failure	101UP110A01E41	DI N02.01..08.25	X06.08.A 04
Common Fault	101UP110A01U41	DI N02.01..08.24	X06.08.A 03
Battery Undervoltage	101UP110A01U43	DI N02.01..08.23	X06.08.A 02



Customer Supply
UPS

101UP110A01M01

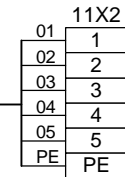

101UP110A02
Battery

101UP110A02W01

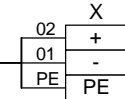

Document: 80019895
Page: 01.000110

This model needs detailed information from Client on terminals to be connected.

Terminals considered now are tentative

101UP110A03
Distribution

101UP110A03W01

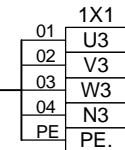

Document: 80019895
Page: 01.000130

LVDB 583ER51MC01

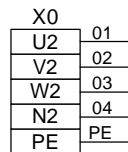

MCC Position:
Unit Type: B28
101UP110Q01 Feeder

101UP110Q01W01

No of cables 1

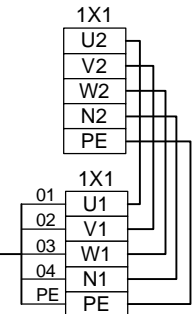

101UP110A01
Control Panel



101UP110A01

UPS
Control Panel

80019895

01.000100

Customer
Supply
UPS

101UP110A01
Control Panel

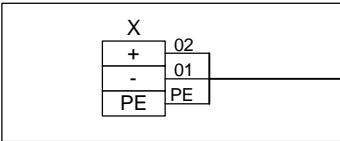

101UP110A02W01

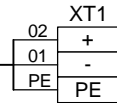

Document: 80019895
Page: 01.000100

This model needs detailed information from Client on terminals to be connected.

Terminals considered now are tentative

101UP110A02
Battery



101UP110A02

UPS
Battery

80019895

01.000110

Tonasa		A UPS 30 KVA	A UPS 30KVA-3	-	5/6/2010 10:32:16 AM	12/22/2011 12:51:58 PM	Customer	A1
<u>List of Consumers (6 A)</u>		<u>Description</u>			<u>Document</u>	<u>Doc. Page</u>		
F1		
F2	582ER51LV01Q02	Incoming from 582ER51	Feeder		80019895	01.001870	Customer	
F3	582ER51MC01Q02	Incoming from 582Er51LV01	Feeder		80019895	01.001920	Supply	
F4	582ER51Q02	Incoming from 582ER52A	Power Feeder		80019895	01.002030		
F5	582ER52AMC03Q02	Incoming	Feeder		80019895	01.002070	UPS	
F6		
F7		
F8		
F9		
F10		
F11		
F12		
F13		
F14		
F15		
F16		
F17		
F18		
F19		
F20		
<u>List of Consumers (10 A)</u>		<u>Description</u>			<u>Document</u>	<u>Doc. Page</u>		
F21	520LG01A11	Control System	Network Interface Box Profibus		80019895	01.000170		
F22	520LG01A12	Control System	Network Interface Box Profibus		80019895	01.000180		
F23	520LG01A13	Control System	Network Interface Box Profibus		80019895	01.000190		
F24	520LG01A15	Control System	Network Interface Box Ethernet		80019895	01.000200		
F25	520LG01A16	Control System	Network Interface Box Ethernet		.	.		
F26		
F27		
F28		
F29		
F30		
<u>List of Consumers (16 A)</u>		<u>Description</u>			<u>Document</u>	<u>Doc. Page</u>		
F31	520LG01A01	Control System	PLC Cpu-Cabinet ER-51		80019895	01.000140		
F32	520LG01A02	Control System	PLC IO-Cabinet ER-51		80019895	01.000150		
F33	520LG01A03	Control System	PLC IO-Cabinet ER-51		80019895	01.000160		
F34	530LG01A04	Control System	PLC IO-Cabinet ER-52A		80019896	01.001920		
F35	530LG01A06	Control System	PLC IO-Cabinet ER-53		80019896	01.001940		
F36		
F37		
F38		
F39		
F40		
<u>List of Consumers (25 A)</u>		<u>Description</u>			<u>Document</u>	<u>Doc. Page</u>		
F41		
							101UP110A03 Distribution	
				101UP110A03	UPS Distribution		80019895	01.000120

Fuse Size and Fuse Numbers are tentative. It is to be corrected based on document from client

520LG01A03

	Address	Position:	Term:
220 VAC		X06.08.A	05L
Fault	101UP110A03U41	DI	05



Customer
Supply

UPS		X3	
02	01	1	
	01	2	
PE		PE	

101UP110A03M01

This model needs detailed information from Client on terminals to be connected.

Terminals considered now are tentative

101UP110A01
Control Panel

1X1	
U3	01
V3	02
W3	03
N3	04
PE.	PE

101UP110A03W01

1X1	
01	1
02	2
03	3
04	4
PE	5

Document: 80019895
Page: 01.000100

101UP110A03
Distribution

FLSmidth Automation
 PLC-TS8205SIE1
 80016926

586CSC01A01
 Server Cabinet 1

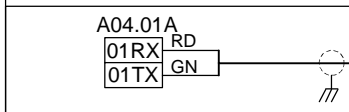

Doc: 80016919
 Page: 08.000390

586CSC01A02
 Server Cabinet 2

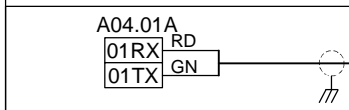

Doc: 80016919
 Page: 08.000400

101UP110A03
 Distribution

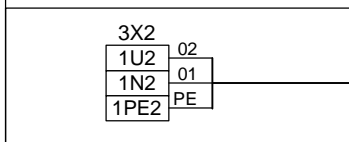

Document: 80019895
 Page: 01.000120

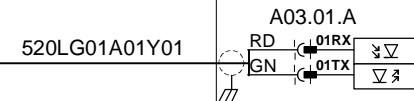

520LG01A01Y01

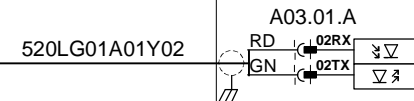

520LG01A01Y02

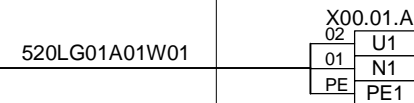

520LG01A01W01

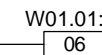

520LG01A01
 PLC Cpu-Cabinet ER-51



520LG01A01

Control System
 PLC Cpu-Cabinet ER-51

80019895

01.000140

FLSmidth Automation
TS8205SIE2
80016926

520LG01A01
PLC Cpu-Cabinet ER-51

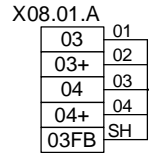

Document: 80019895
Page: 01.000140

520LG01A01
PLC Cpu-Cabinet ER-51

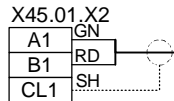

101UP110A03
Distribution

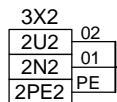

Document: 80019895
Page: 01.000120

520LG01A02I01

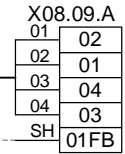

520LG01A02Y01

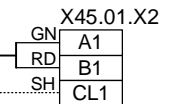

520LG01A02W01

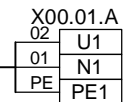

W01.01:
06



520LG01A02

PLC IO-Cabinet ER-51

FLSmidth Automation
TS8205SIE2
80016926

520LG01A02
PLC IO-Cabinet ER-51

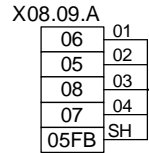

520LG01A03I01

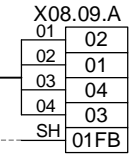

Document: 80019895
Page: 01.000150

520LG01A02
PLC IO-Cabinet ER-51

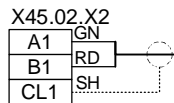

520LG01A03Y01

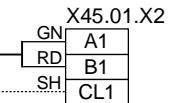

101UP110A03
Distribution

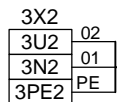

520LG01A03W01

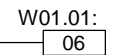
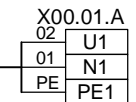

Document: 80019895
Page: 01.000120



520LG01A03
PLC IO-Cabinet ER-51



520LG01A03

Control System
PLC IO-Cabinet ER-51

80019895

01.000160

101UP110A03
Distribution

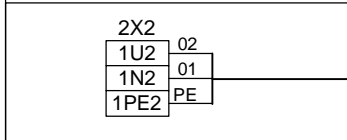

Document: 80019895
Page: 01.000120

520LG01A01
PLC Cpu-Cabinet ER-51

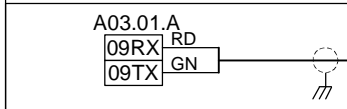

Doc: 80019895
Page: 01.000140

External Cable Connections

	Row	Unit Code	Description	Document	Page
Outgoing Fiber Profibus	A02.01.A	520LG01A13	Network Interface Box Profibus	80019895	01.000190
Outgoing Electric Profibus	X41.01.A	521BW01A01	Control Panel	80019895	01.000710
Outgoing Electric Profibus	R10.01.

520LG01A11M01

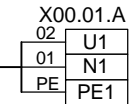

520LG01A11Y01

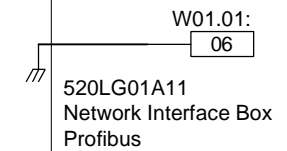
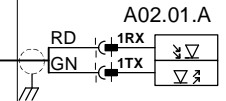

101UP110A03
Distribution

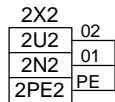

Document: 80019895
Page: 01.000120

520LG01A01
PLC Cpu-Cabinet ER-51

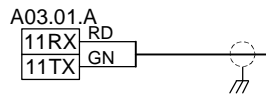

Doc: 80019895
Page: 01.000140

External Cable Connections

	Row	Unit Code	Description	Document	Page
Outgoing Fiber Profibus	A02.01.A
Outgoing Electric Profibus	X41.01.A	582ER52AMC03Q02	Feeder	80019895	01.002070
Outgoing Electric Profibus	R10.01.

520LG01A12M01

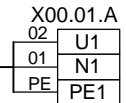

520LG01A12Y01

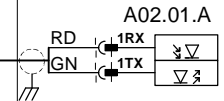

W01.01:
06

520LG01A12
Network Interface Box
Profibus

101UP110A03
Distribution

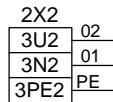

520LG01A13M01

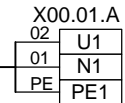

Document: 80019895
Page: 01.000120

520LG01A11
Network Interface Box Profibus

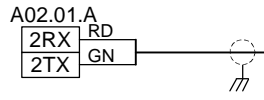

520LG01A13Y01

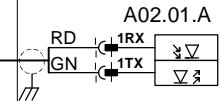

Doc: 80019895
Page: 01.000170

External Cable Connections

	Row	Unit Code	Description	Document	Page
Outgoing Fiber Profibus	A02.01.A
Outgoing Electric Profibus	X41.01.A	523AF01U01	Frequency Converter	80019895	01.001350
Outgoing Electric Profibus	R10.01.

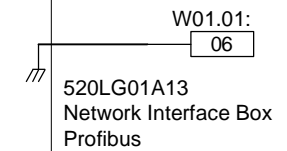

101UP110A03
Distribution

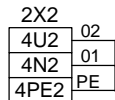

520LG01A15M01

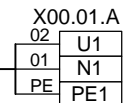

Document: 80019895
Page: 01.000120

520LG01A01
PLC Cpu-Cabinet ER-51

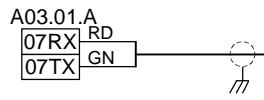

520LG01A15Y01

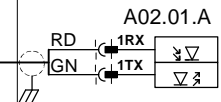

Doc: 80019895
Page: 01.000140

External Cable Connections

	Row	Unit Code	Description	Document	Page
Outgoing Fiber Profibus	A02.01.A
Outgoing Electric Profibus
Outgoing Electric Profibus

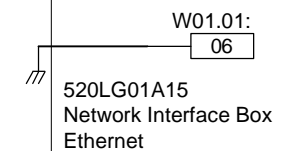

Tonasa	S Emergency Stop (process)	S Emergency Stop (process)	-	5/6/2010 10:29:01 AM	12/22/2011 12:52:05 PM	Customer	A1
--------	----------------------------	----------------------------	---	----------------------	------------------------	----------	----

520LG01A01

		Address	Position:	Term:	02	01
220 VAC			X04.01.A	01L		
Emergency Stop	520LG01S01S71	DI	N01.01..09.19	X04.01.A	01	

⊕

520LG01S01M01

Customer
Supply
Dept. Emergency Stop

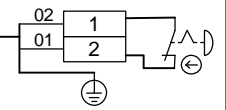

520LG01S01
In CCR



520LG01S01

Dept. Emergency Stop
In CCR

80019895

01.000210

Tonasa	S Emergency Stop (process)	S Emergency Stop (process)	-	5/6/2010 10:29:27 AM	12/22/2011 12:52:05 PM	Customer	A1
--------	----------------------------	----------------------------	---	----------------------	------------------------	----------	----

520LG01A01

		Address	Position:	Term:	
220 VAC			X04.01.A	02L	02
Emergency Stop	520LG01S02S71	DI	N01.01..09.20	02	01

⊕

520LG01S02M01

Customer
Supply
Dept. Emergency Stop

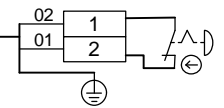

520LG01S02
On 311Bin



520LG01S02

Dept. Emergency Stop
On 311Bin

80019895

01.000220

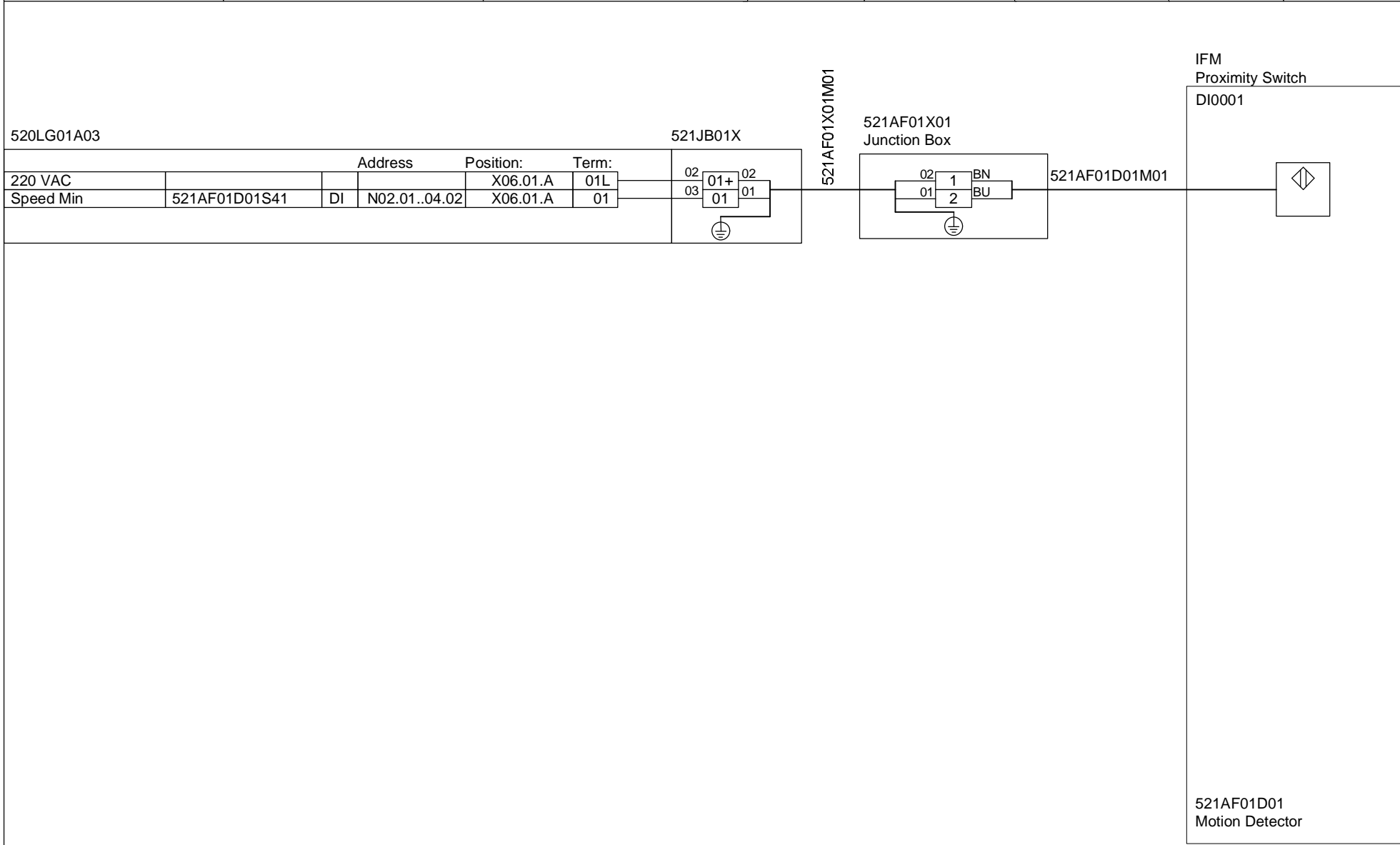

520LG01A03		521JB01X			
	Address	Position:	Term:		
220 VAC		X06.01.A	01L	02	01+
Speed Min	521AF01D01S41	X06.01.A	01	03	01

LVDB 582ER51MC01

521AF01S02
Start/Stop/E-stop

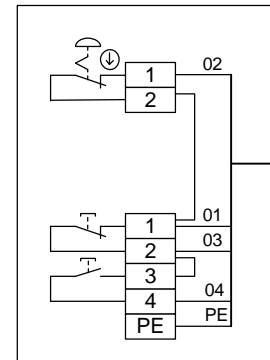

521AF01S02M01

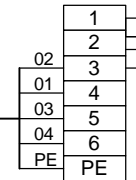

521AF01E01
Heating Element
kW (Derated)
kW

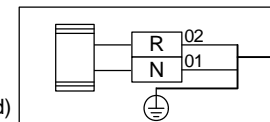

521AF01E01M01

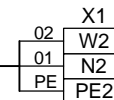

Position:
Unit Conn. Type: B22
Net: 520LG01:DP5
Node: MCC/MDB 2.011
521AF01Q02 Motor Starter



521AF01E01

Apron Feeder
Heating Element

80019895

01.000240

LVDB 582ER51MC01

521AF01S01
Start/Stop/E-stop

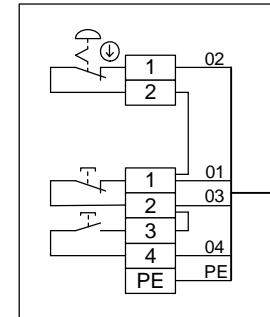

521AF01S01M01

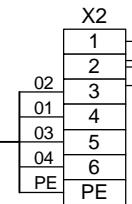

521AF01M01
Motor

Document: 80019895
Page: 01.000260

521AF01M01C01

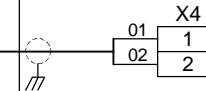

521AF01U01
Frequency Converter

Document: 80019895
Page: 01.000260

521AF01U01W01

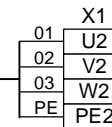

No of cables 1

MCC Position:
Unit Type: B15.1-UD-TH
Net: 520LG01:DP5
Node: MCC/MDB 2.012
521AF01Q01
Motor Starter

ABB
Frequency Drive
ACS850-04-521A-5+E210+J410+K454

582ER51MC01F01
Feeder

521AF01U01M01

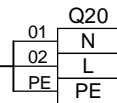

Document: 80019895
Page: 01.001890

521AF01Q01
Motor Starter

521AF01M01C01

Doc: 80019895
Page: 01.000250

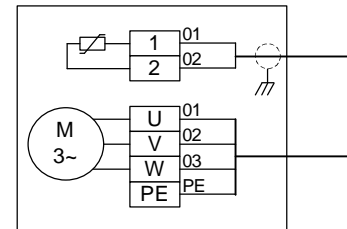

521AF01M01
Motor
200 kW

521AF01M01W01

No of cables 2

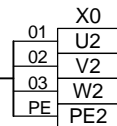

521AF01Q01
Motor Starter

521AF01U01W01

No of cables 1

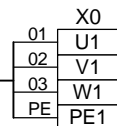

Doc: 80019895
Page: 01.000250

Net: 520LG01:DP3
Node: Field Device.011
521AF01U01
Frequency Converter



521AF01U01

Apron Feeder
Frequency Converter

80019895

01.000260

ABB
Frequency Drive
ACS850-04-521A-
5+E210+J410+K454

521CR01Q02
Power Feeder

521AF01U01Y01

Document: 80019895
Page: 01.000970

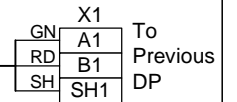

520LG01A01
PLC Cpu-Cabinet ER-51

520LG01A01Y03

Document: 80019895
Page: 01.000140

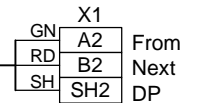

521AF01U01
Frequency Converter



521AF01U01

Apron Feeder
Frequency Converter

80019895

01.000270

521BC01S01
Start/Stop/E-stop

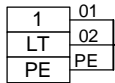

Document: 80019895
Page: 01.000320

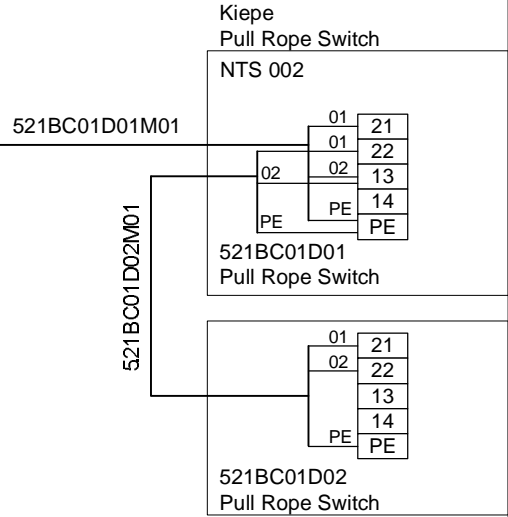

Tonasa	S Kiepe Sway Detector 04 P. 2 St. LSC	S Kiepe Sway Detector 4 P. 2 St. LSC	VCI-IN	9/28/2010 5:53:00 AM	12/29/2011 8:53:08 AM	Customer	A1
--------	---------------------------------------	--------------------------------------	--------	----------------------	-----------------------	----------	----

520LG01A03

521JB03X

	Address	Position:	Term:	
220 VAC			01L	02 01+ 02
Sway Max 1	521BC01D03Z41	DI	X06.03.A	03 01 01
Sway Max 2	521BC01D03Z42	DI	X06.03.A	06 02 03

Kiepe
Off Track Limit Switch

SLS 011

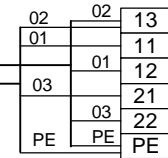

521BC01D03M01

521BC01D04M01

521BC01D05M01

521BC01D06M01

521BC01D03
Sway Detector

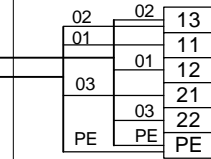

521BC01D04
Sway Detector

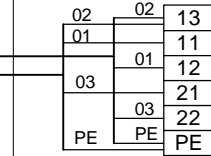

521BC01D05
Sway Detector

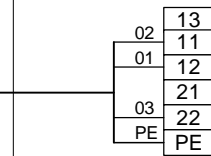

521BC01D06
Sway Detector



521BC01D03

Discharge Belt conveyor
Sway Detector

80019895

01.000290

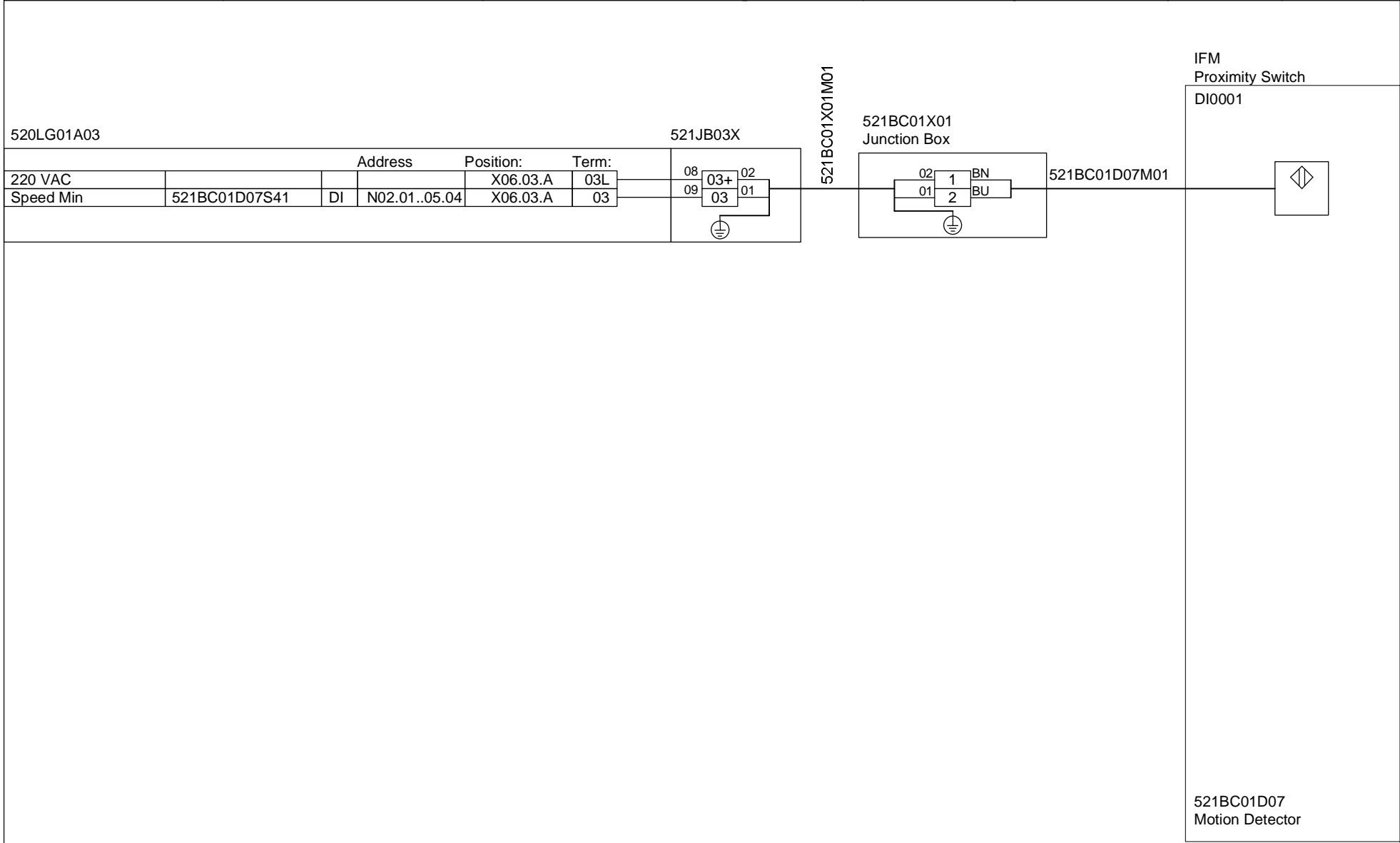

520LG01A03

521JB03X

	Address	Position:	Term:
220 VAC		X06.03.A	04L
Temperature High	521BC01D08T41	DI	X06.03.A
		N02.01..05.05	04

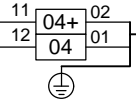

521BC01D08M01

Panasonic
Limit Switch

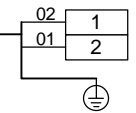

521BC01D08
Temperature



521BC01D08

Discharge BC Hydraulic Coupling
Temperature

80019895

01.000310

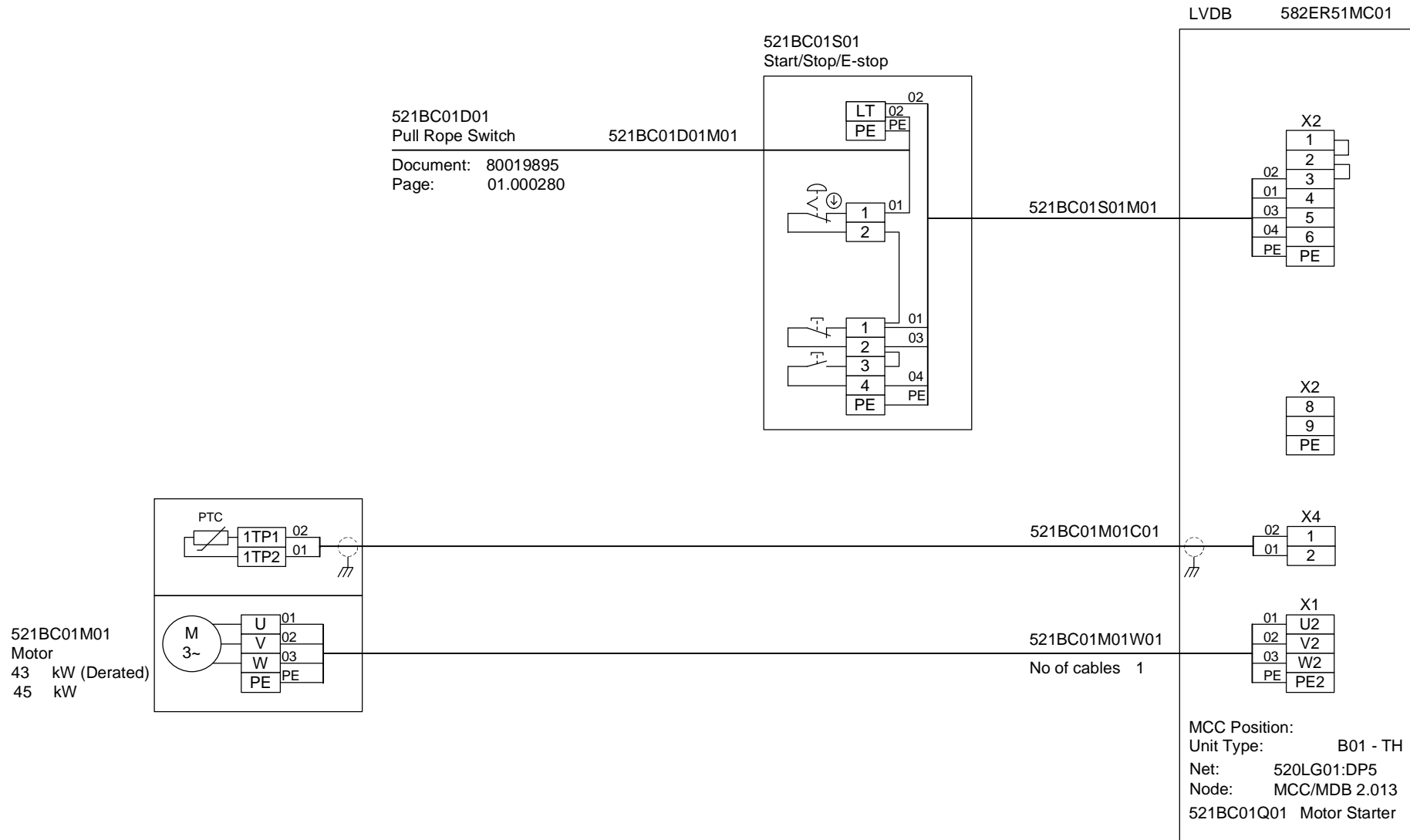

521BC02S11
Emergency Stop

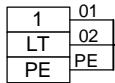

Document: 80019895
Page: 01.000430

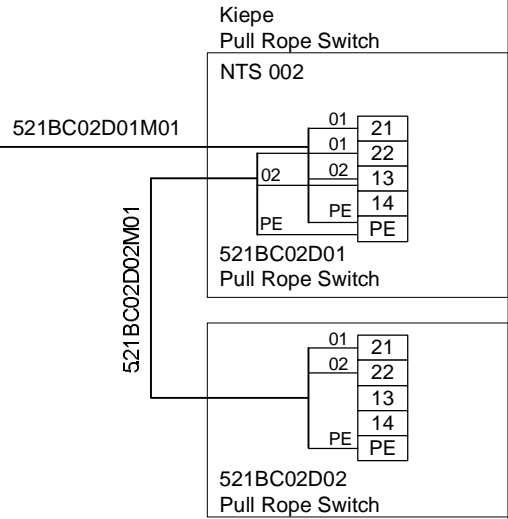

520LG01A03

521JB04X

	Address	Position:	Term:
220 VAC		X06.04.A	01L
Sway Max 1	521BC02D03Z41	N02.01..05.22	X06.04.A 01
Sway Max 2	521BC02D03Z42	N02.01..05.23	X06.04.A 02

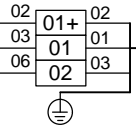

Kiepe
Off Track Limit Switch

SLS 011

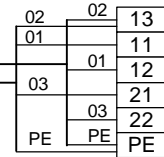

521BC02D03M01

521BC02D03
Sway Detector

521BC02D04M01

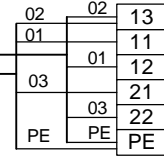

521BC02D05M01

521BC02D04
Sway Detector

521BC02D06M01

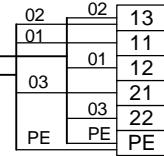

521BC02D05
Sway Detector

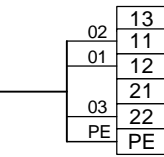

521BC02D06
Sway Detector



521BC02D03

Belt Conveyor
Sway Detector

80019895

01.000340

520LG01A03

521JB04X

	Address	Position:	Term:	
0/220 VAC		X06.04.A	03N	07
220 VAC		X06.04.A	03L	08
Speed Min	521BC02D07S41	DI N02.01..05.24	X06.04.A	03

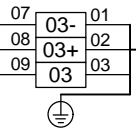

Milltronics
ZSS

521BC02D07M01

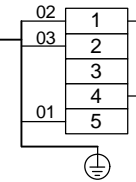

521BC02D07
Motion Detector



521BC02D07

Belt Conveyor
Motion Detector

80019895

01.000350

520LG01A03

521JB04X

Panasonic
Limit Switch

	Address	Position:	Term:
220 VAC		X06.04.A	04L
Temperature High	521BC02D08T41	DI	N02.01..05.25
		X06.04.A	04

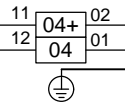

521BC02D08M01

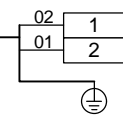

521BC02D08
Temperature



521BC02D08

Belt Conveyor Hydraulic Coupling
Temperature

80019895

01.000360

520LG01A03

521JB04X

	Address	Position:	Term:
220 VAC		X06.04.A	05L
Temperature High	521BC02D09T41	DI	X06.04.A 05

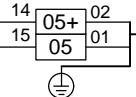

521BC02D09M01

Panasonic
Limit Switch

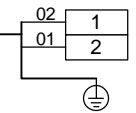

521BC02D09
Temperature



521BC02D09

Belt Conveyor Hydraulic Coupling
Temperature

80019895

01.000370

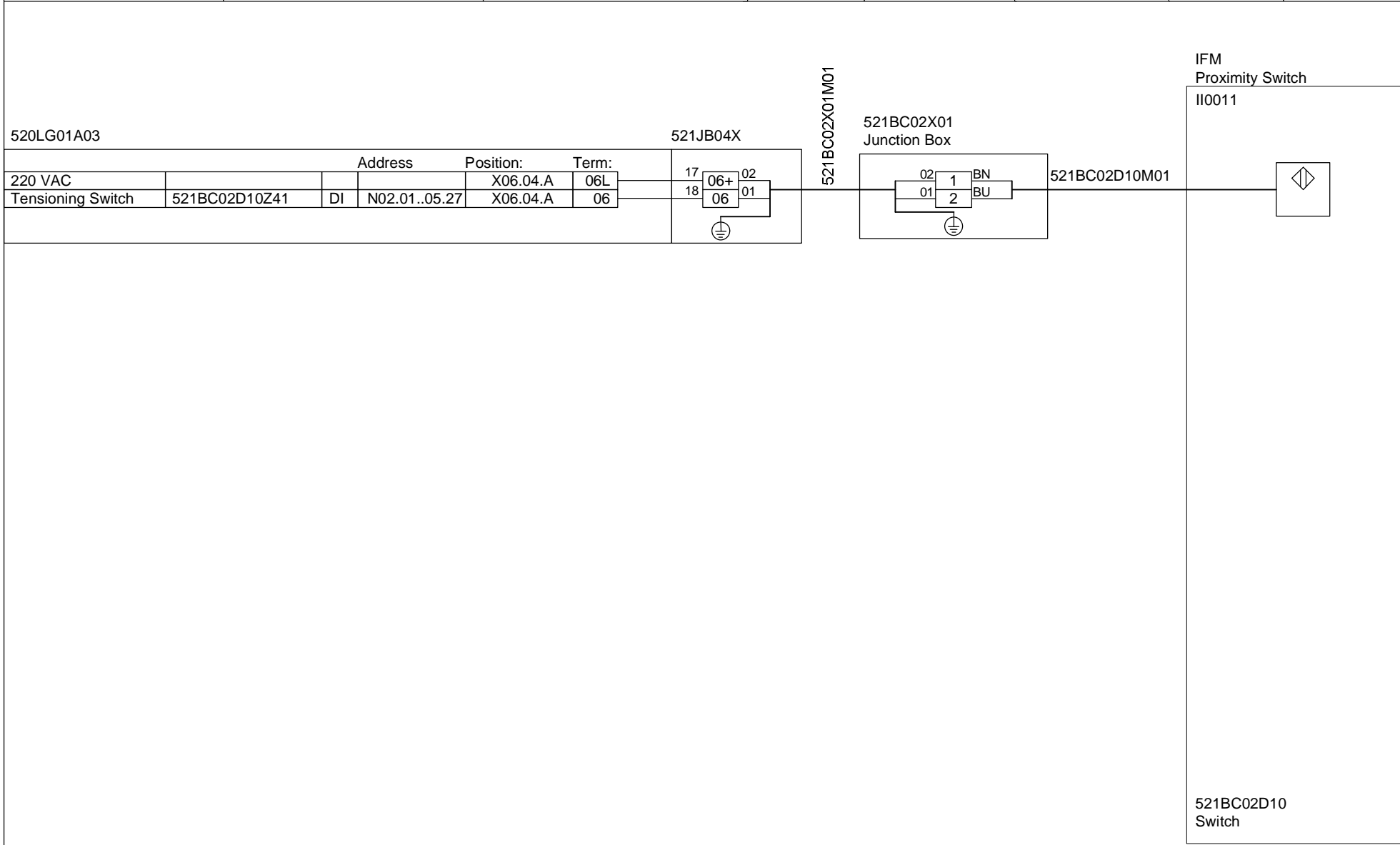

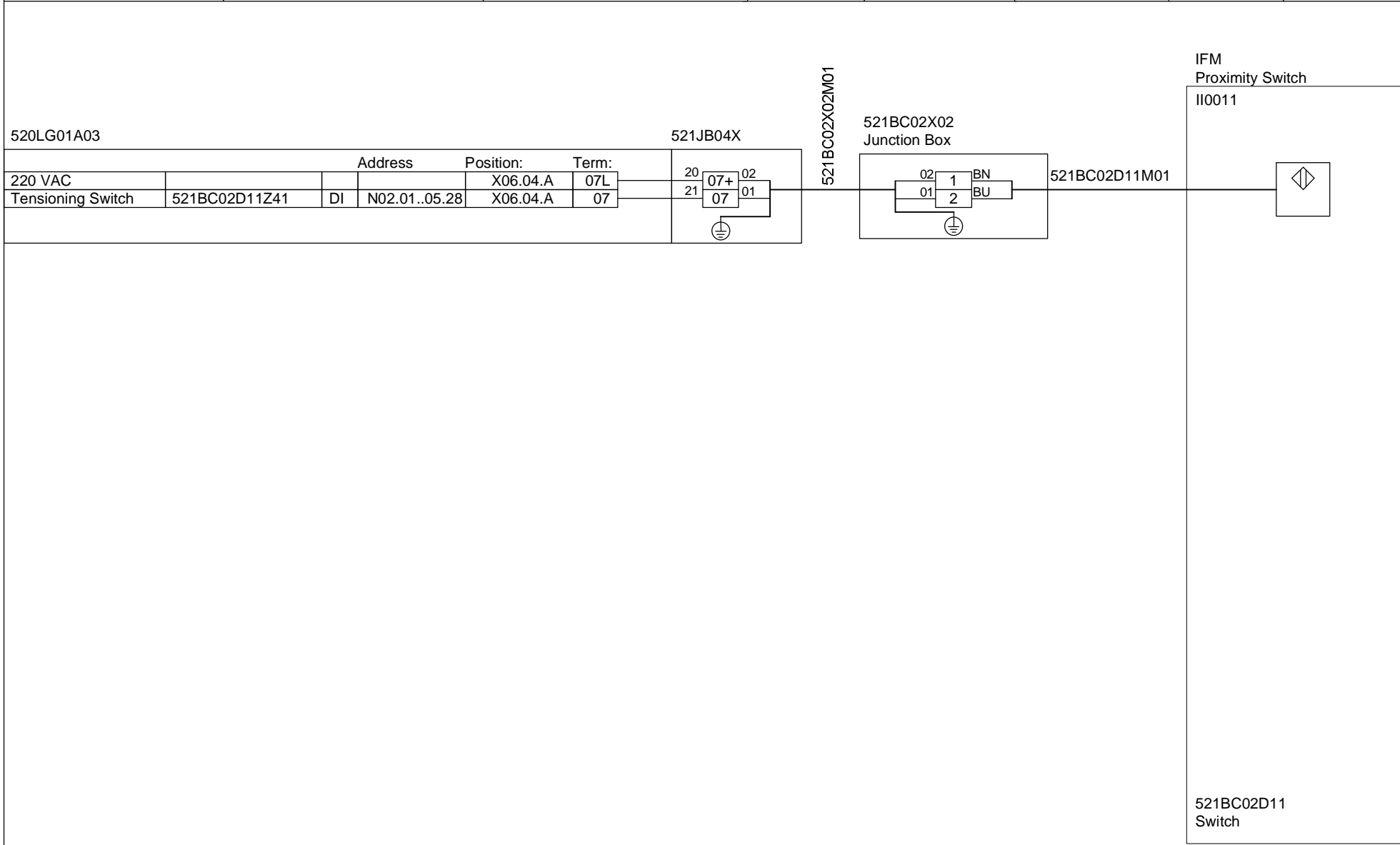

LVDB 582ER51MC01

521BC02S03
Start/Stop/E-stop

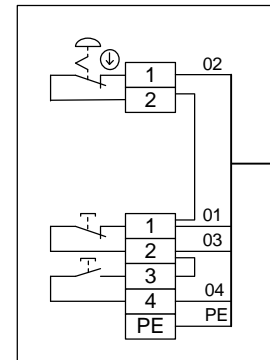

521BC02S03M01

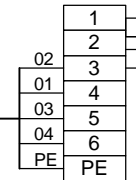

521BC02E01
Heating Element
kW (Derated)
kW

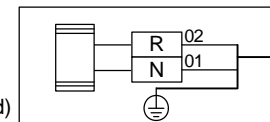

521BC02E01M01

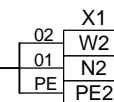

Position:
Unit Conn. Type: B22
Net: 520LG01:DP5
Node: MCC/MDB 2.016
521BC02Q03 Motor Starter



521BC02E01

Belt Conveyor
Heating Element -1

80019895

01.000400

LVDB 582ER51MC01

521BC02S04
Start/Stop/E-stop

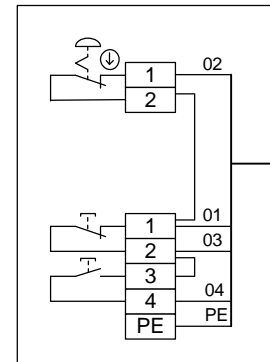

521BC02S04M01

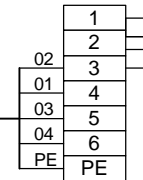

521BC02E02
Heating Element
kW (Derated)
kW

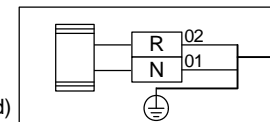

521BC02E02M01

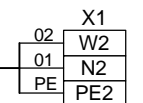

Position:
Unit Conn. Type: B22
Net: 520LG01:DP5
Node: MCC/MDB 2.018
521BC02Q04 Motor Starter



521BC02E02

Belt Conveyor
Heating Element -2

80019895

01.000410

LVDB 582ER51MC01

521BC02S01
Start/Stop/E-stop

521BC02S11
Emergency Stop 521BC02S11M01
Document: 80019895
Page: 01.000430

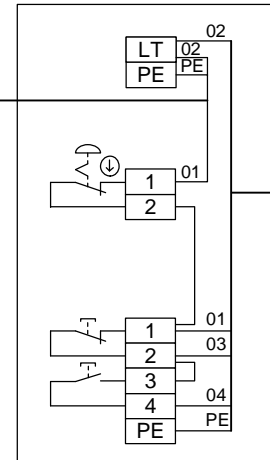

521BC02S01M01

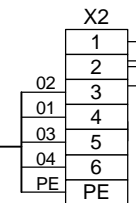

521BC02Q02
Motor Starter
Document: 80019895
Page: 01.000430

521BC02Q02M01

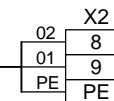

521BC02M01
Motor
106 kW (Derated)
110 kW

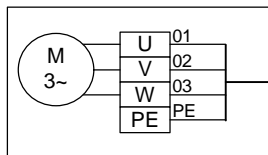

521BC02M01W01

No of cables 1

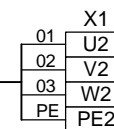

MCC Position:
Unit Type: B01 - PM
Net: 520LG01:DP5
Node: MCC/MDB 2.014
521BC02Q01
Motor Starter



521BC02M01

Belt Conveyor
Motor

80019895

01.000420

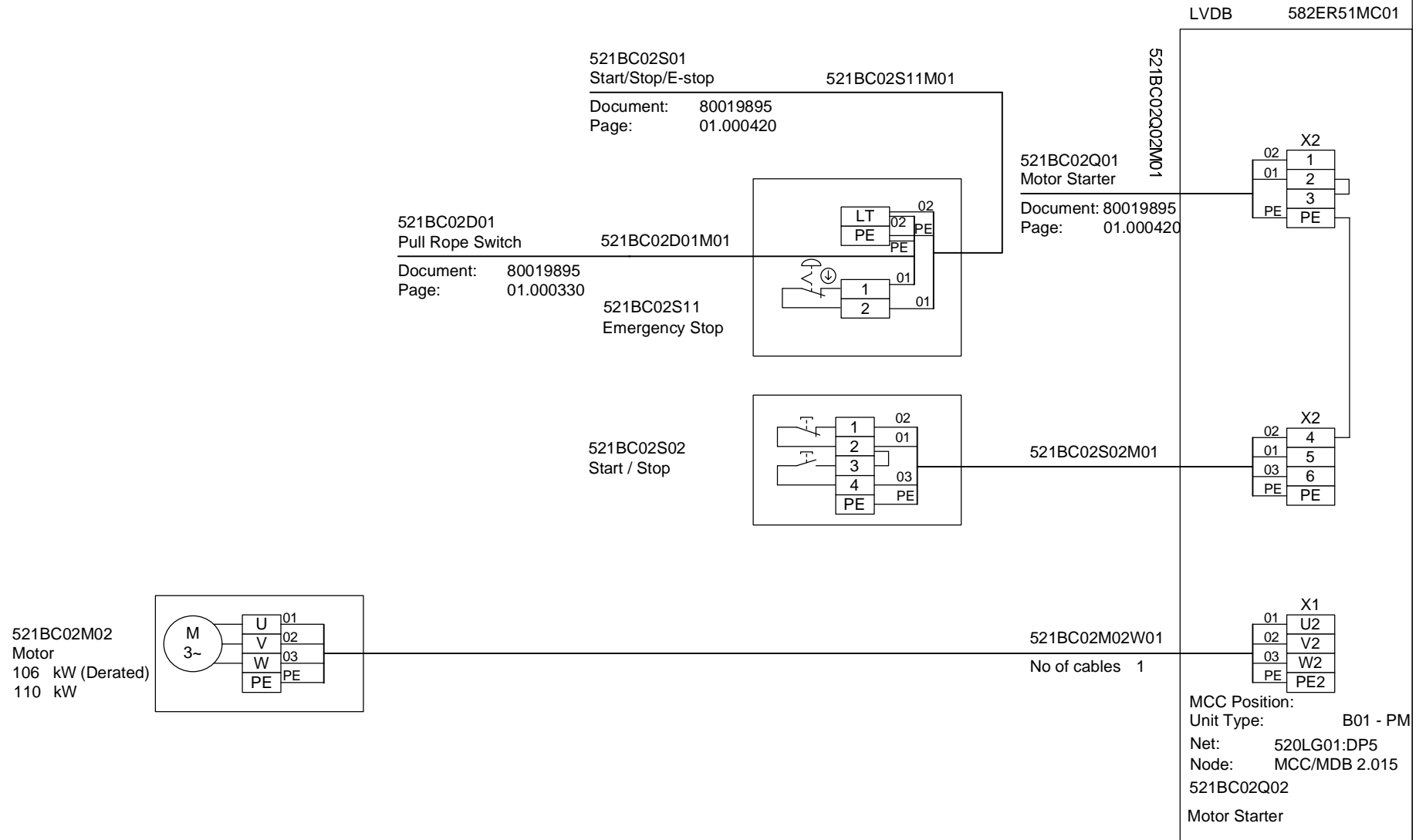

520LG01A02

521JB02A

	Address	Position	Term:
+24 VDC		X05.02.A	13+
Winding Temp. -U	521BC02N21T01	AI	N02.01..08.12 X05.02.A 13
+24 VDC		X05.02.A	14+
Winding Temp. -V	521BC02N22T01	AI	N02.01..08.14 X05.02.A 14
+24 VDC		X05.02.A	15+
Winding Temp. -W	521BC02N23T01	AI	N02.01..08.16 X05.02.A 15

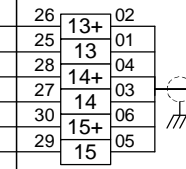

521BC02N21C01

Customer

Supply

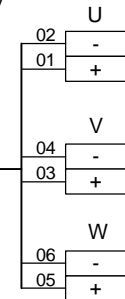

This model needs detailed information from Client on terminals to be connected.

Terminals considered now are tentative

Range: 0 - 150 °C

521BC02N21
Temperature

520LG01A02

521JB03A

	Address	Position	Term:
+24 VDC		X05.03.A	01+
Winding Temp. -U	521BC02N24T01	N02.01..10.02	X05.03.A 01
+24 VDC		X05.03.A	02+
Winding Temp. -V	521BC02N25T01	N02.01..10.04	X05.03.A 02
+24 VDC		X05.03.A	03+
Winding Temp. -W	521BC02N26T01	N02.01..10.06	X05.03.A 03

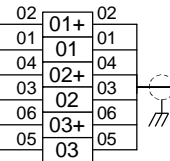

521BC02N24C01

Customer
Supply

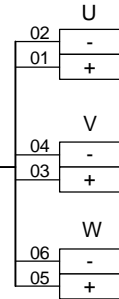

This model needs detailed information from Client on terminals to be connected.

Terminals considered now are tentative

Range: 0 - 150 °C

521BC02N24
Temperature

521BC03S01
Start/Stop/E-stop

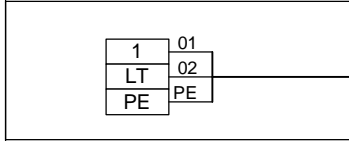

Document: 80019895
Page: 01.000530

521BC03D01M01

Kiepe
Pull Rope Switch
NTS 002

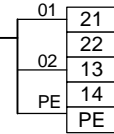

521BC03D01
Pull Rope Switch

520LG01A03

521JB04X

	Address	Position:	Term:	
220 VAC			08L	23 08+ 02
Sway Max 1	521BC03D02Z41	DI N02.01..05.29	X06.04.A	08 01
Sway Max 2	521BC03D02Z42	DI N02.01..05.32	X06.04.A	09 03

Kiepe
Off Track Limit Switch

SLS 011

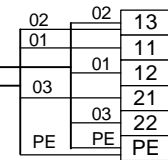

521BC03D02M01

521BC03D03M01

521BC03D04M01

521BC03D05M01

521BC03D02
Sway Detector

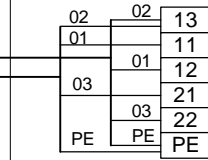

521BC03D03
Sway Detector

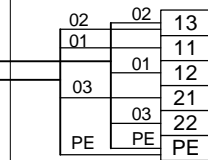

521BC03D04
Sway Detector



521BC03D05
Sway Detector



521BC03D02

Belt Conveyor
Sway Detector

80019895

01.000470

Tonasa	DT Panasonic	DT Panasonic	-	10/13/2010 12:06:02 PM	12/22/2011 12:52:23 PM	Customer	A1
--------	--------------	--------------	---	------------------------	------------------------	----------	----

520LG01A03

521JB04X

Panasonic
Limit Switch

	Address	Position:	Term:
220 VAC		X06.04.A	10L
Temperature High	521BC03D06T41	DI	N02.01..05.33
		X06.04.A	10

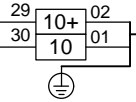

521BC03D06M01

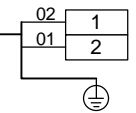

521BC03D06
Temperature

	521BC03D06	Belt Conveyor Hydraulic Coupling Temperature	80019895	01.000480
--	------------	---	----------	-----------

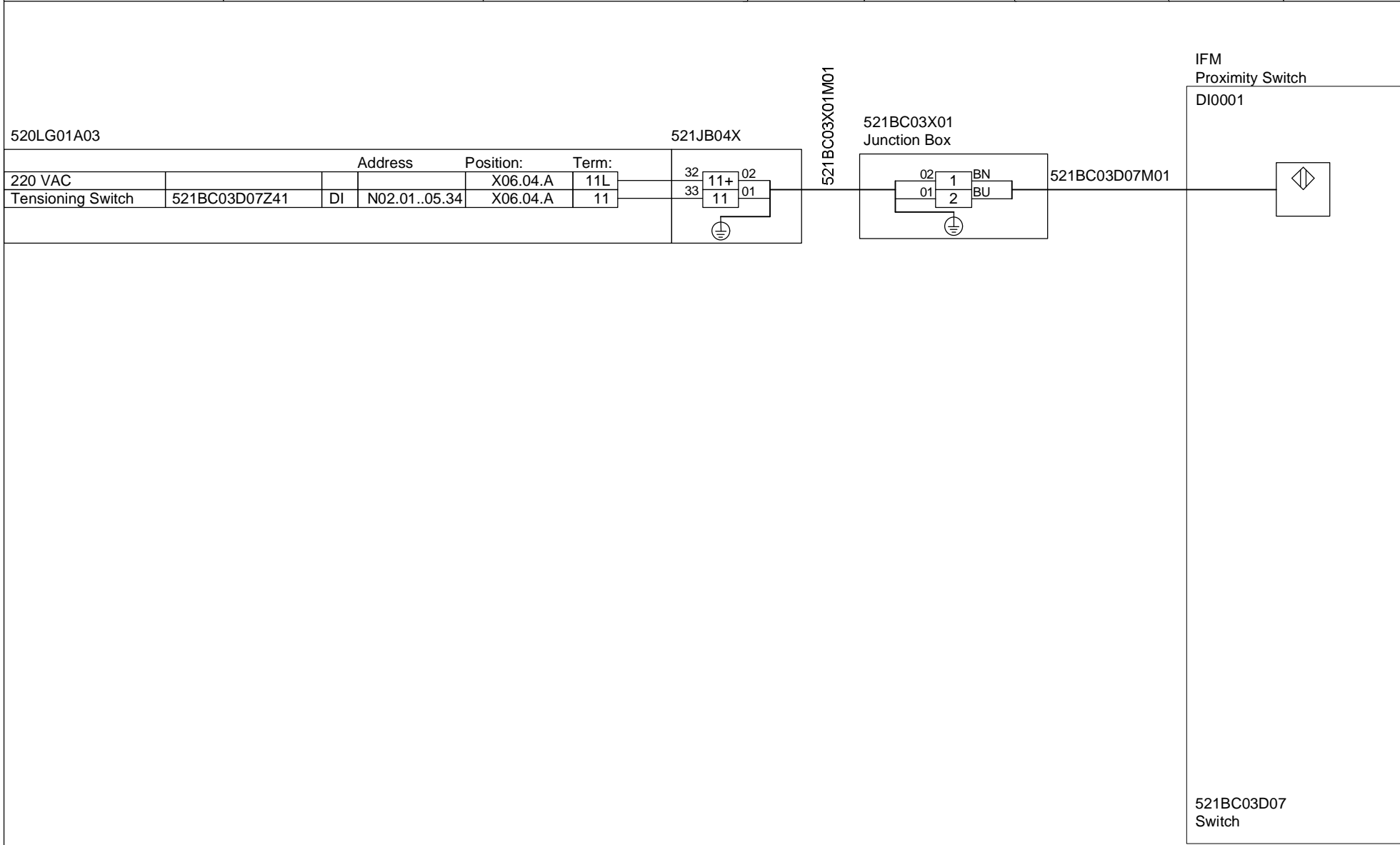

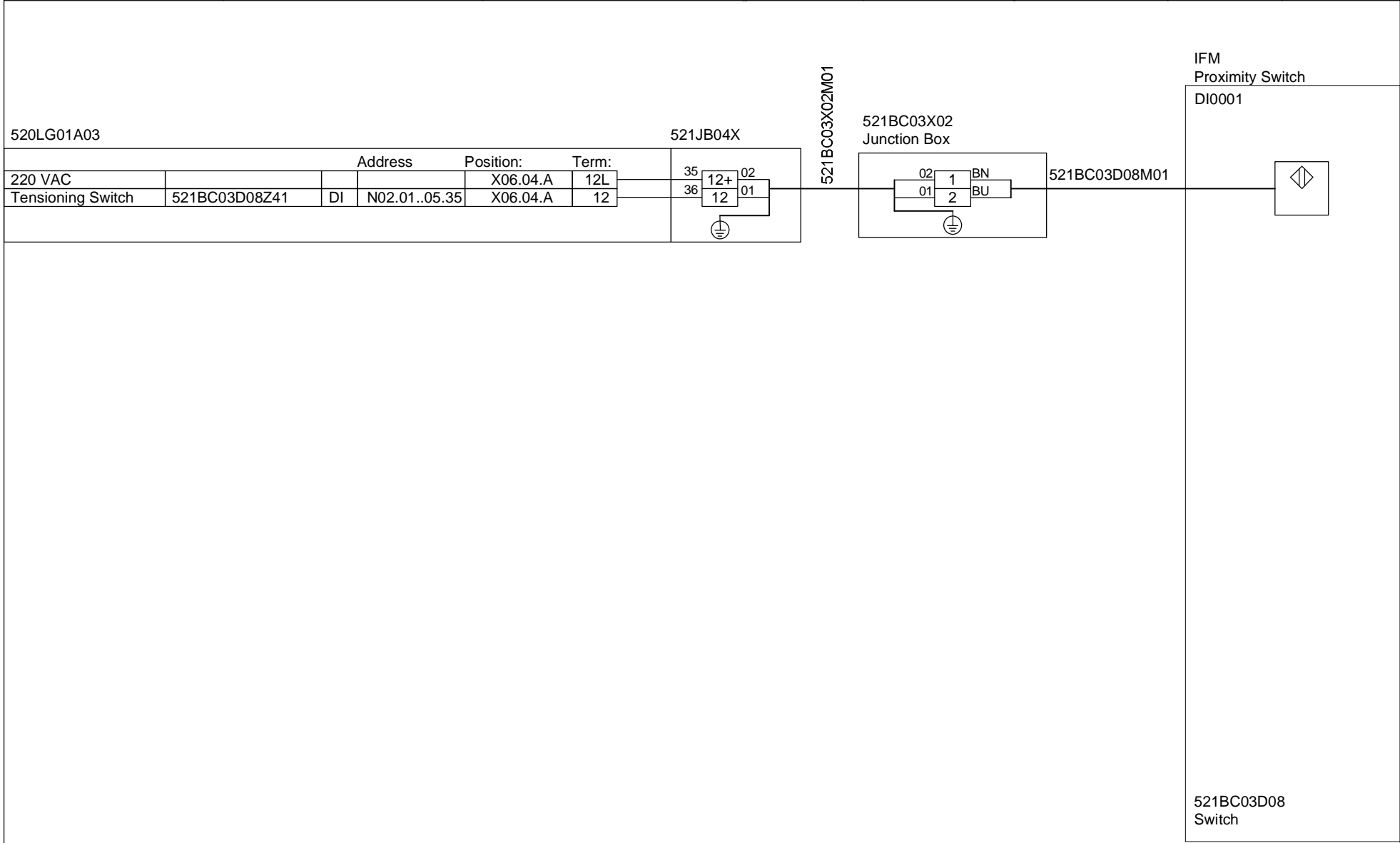

520LG01A03

521JB04X

	Address	Position:	Term:	
0/220 VAC		X06.04.A	13N	37
220 VAC		X06.04.A	13L	38
Speed Min	521BC03D09S41	DI	N02.01..05.36	X06.04.A
				13

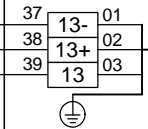

521BC03D09M01

Milltronics
ZSS

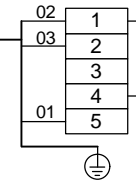

521BC03D09
Motion Detector



521BC03D09

Belt Conveyor
Motion Detector

80019895

01.000510

LVDB 582ER51MC01

521BC03S02
Start/Stop/E-stop

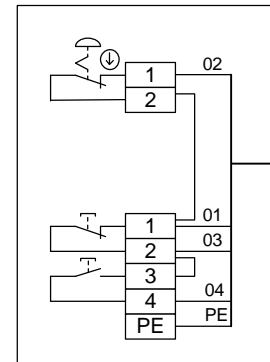

521BC03S02M01

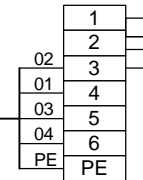

521BC03E01
Heating Element
kW (Derated)
kW

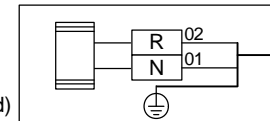

521BC03E01M01

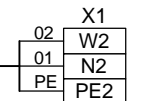

Position:
Unit Conn. Type: B22
Net: 520LG01:DP5
Node: MCC/MDB 2.020
521BC03Q02 Motor Starter



521BC03E01

Belt Conveyor
Heating Element

80019895

01.000520

LVDB 582ER51MC01

521BC03S01
Start/Stop/E-stop

521BC03D01
Pull Rope Switch

521BC03D01M01

Document: 80019895
Page: 01.000460

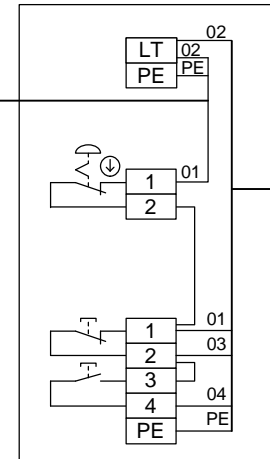

521BC03S01M01

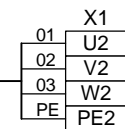
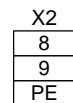
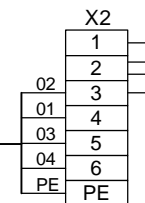

521BC03M01
Motor
72 kW (Derated)
75 kW

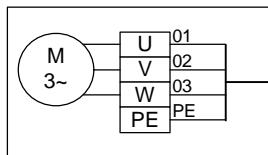

521BC03M01W01

No of cables 1

MCC Position:
Unit Type: B01 - PM
Net: 520LG01:DP5
Node: MCC/MDb 2.019
521BC03Q01 Motor Starter

521BC04S11
Emergency Stop

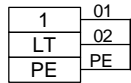

Document: 80019895
Page: 01.000640

Kiepe
Pull Rope Switch
NTS 002

521BC04D01M01

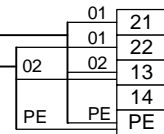

521BC04D02M01

521BC04D01
Pull Rope Switch

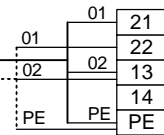

Cable List: Pull Rope switches

- 521BC04D03M01
- 521BC04D04M01
- 521BC04D05M01
- 521BC04D06M01
- 521BC04D07M01

521BC04D08M01

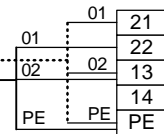

521BC04D08
Pull Rope Switch

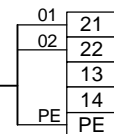

520LG01A03

521JB05X

	Address	Position:	Term:
220 VAC		X06.05.A	01L
Sway Max 1	521BC04D09Z41	DI N02.01..07.02	X06.05.A 01
Sway Max 2	521BC04D09Z42	DI N02.01..07.03	X06.05.A 02

Kiepe
Off Track Limit Switch

SLS 011

521BC04D09M01

521BC04D10M01

521BC04D14M01

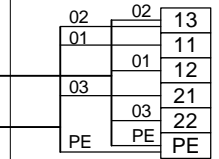

521BC04D09
Sway Detector

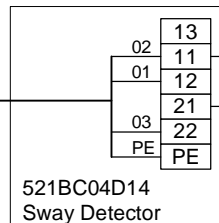
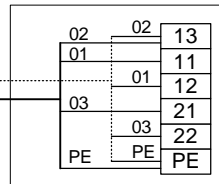
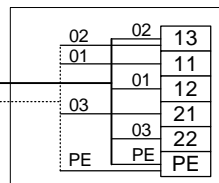

Cable List:

- 521BC04D11M01
- 521BC04D12M01
- 521BC04D13M01



521BC04D09

Belt Conveyor
Sway Detector

80019895

01.000550

520LG01A03

521JB05X

	Address	Position:	Term:		
0/220 VAC		X06.05.A	03N	07	03-
220 VAC		X06.05.A	03L	08	03+
Speed Min	521BC04D15S41	DI	N02.01..07.04	X06.05.A	03

Milltronics
ZSS

521BC04D15M01

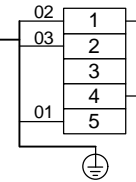

521BC04D15
Motion Detector



521BC04D15

Belt Conveyor
Motion Detector

80019895

01.000560

520LG01A03

521JB05X

Panasonic
Limit Switch

	Address	Position:	Term:
220 VAC		X06.05.A	04L
Temperature High	521BC04D16T41	DI	N02.01..07.05
		X06.05.A	04

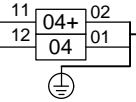

521BC04D16M01

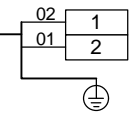

521BC04D16
Temperature



521BC04D16

Belt Conveyor Hydraulic Coupling
Temperature

80019895

01.000570

520LG01A03

521JB05X

Panasonic
Limit Switch

	Address	Position:	Term:
220 VAC		X06.05.A	05L
Temperature High	521BC04D17T41	DI	N02.01..07.06
		X06.05.A	05

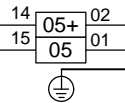

521BC04D17M01

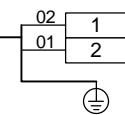

521BC04D17
Temperature



521BC04D17

Belt Conveyor Hydraulic Coupling
Temperature

80019895

01.000580

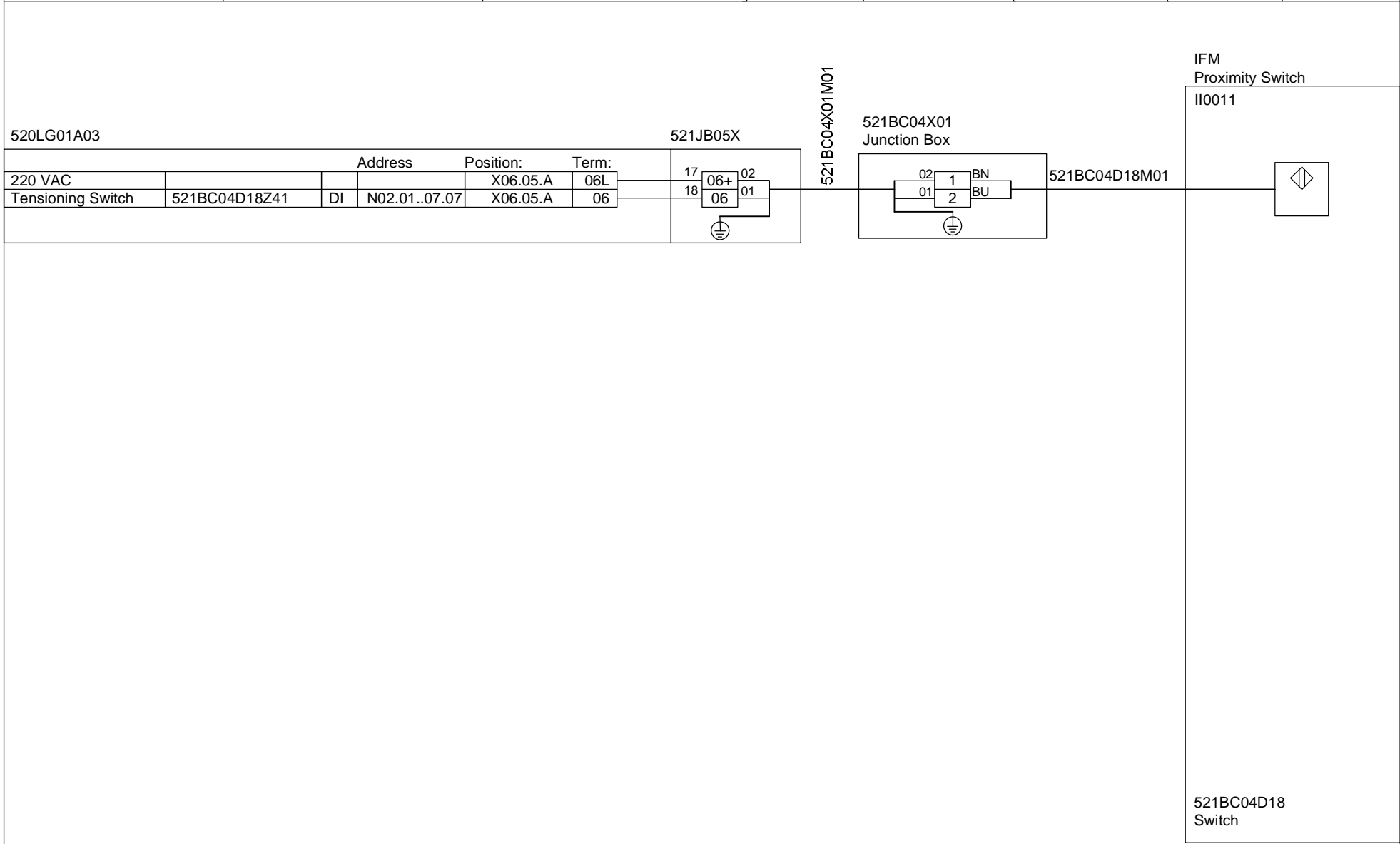

520LG01A03

521JB05X

521BC04X01M01

521BC04X01
Junction Box

IFM
Proximity Switch
II0011

	Address	Position:	Term:
220 VAC		X06.05.A	06L
Tensioning Switch	521BC04D18Z41	DI N02.01..07.07	X06.05.A 06

521BC04D18M01

521BC04D18
Switch



521BC04D18

Belt Conveyor Upper clamping stroke
Switch

80019895

01.000590

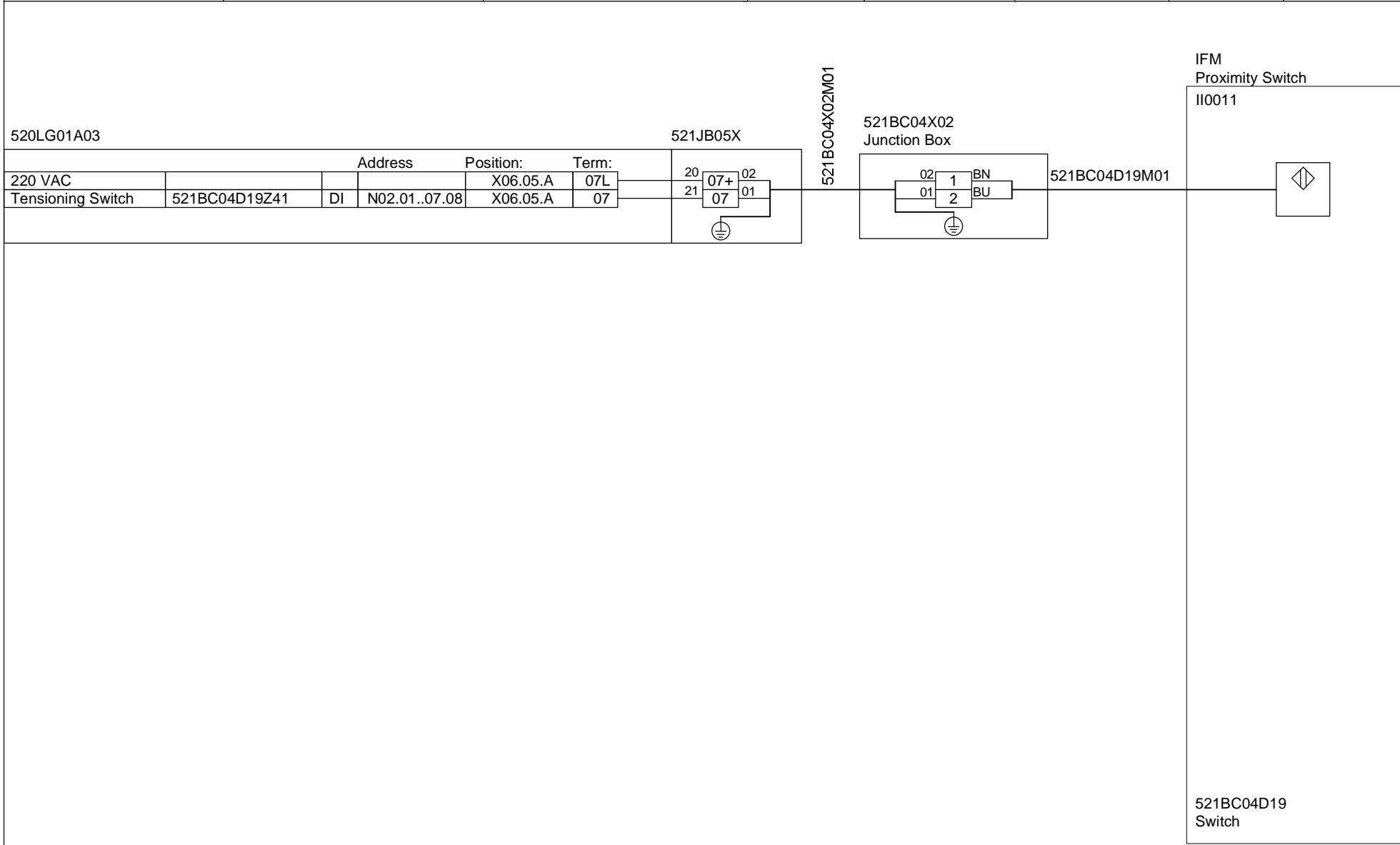

LVDB 582ER51MC01

521BC04S03
Start/Stop/E-stop

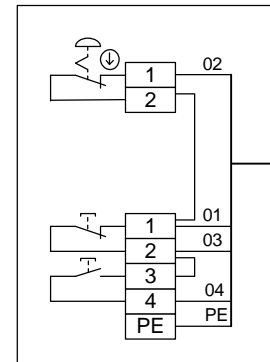

521BC04S03M01

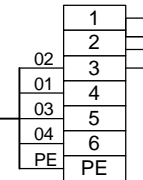

521BC04E01
Heating Element
kW (Derated)
kW

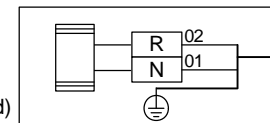

521BC04E01M01

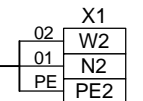

Position:
Unit Conn. Type: B22
Net: 520LG01:DP5
Node: MCC/MDB 2.023
521BC04Q03 Motor Starter



521BC04E01

Belt Conveyor
Heating Element -1

80019895

01.000610

LVDB 582ER51MC01

521BC04S04
Start/Stop/E-stop

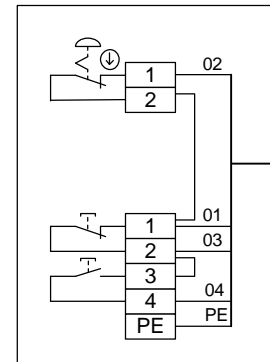

521BC04S04M01

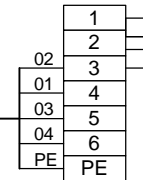

521BC04E02
Heating Element
kW (Derated)
kW

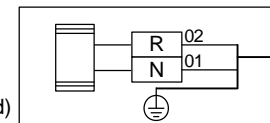

521BC04E02M01

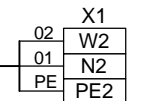

Position:
Unit Conn. Type: B22
Net: 520LG01:DP5
Node: MCC/MDB 2.024
521BC04Q04 Motor Starter



521BC04E02

Belt Conveyor
Heating Element -2

80019895

01.000620

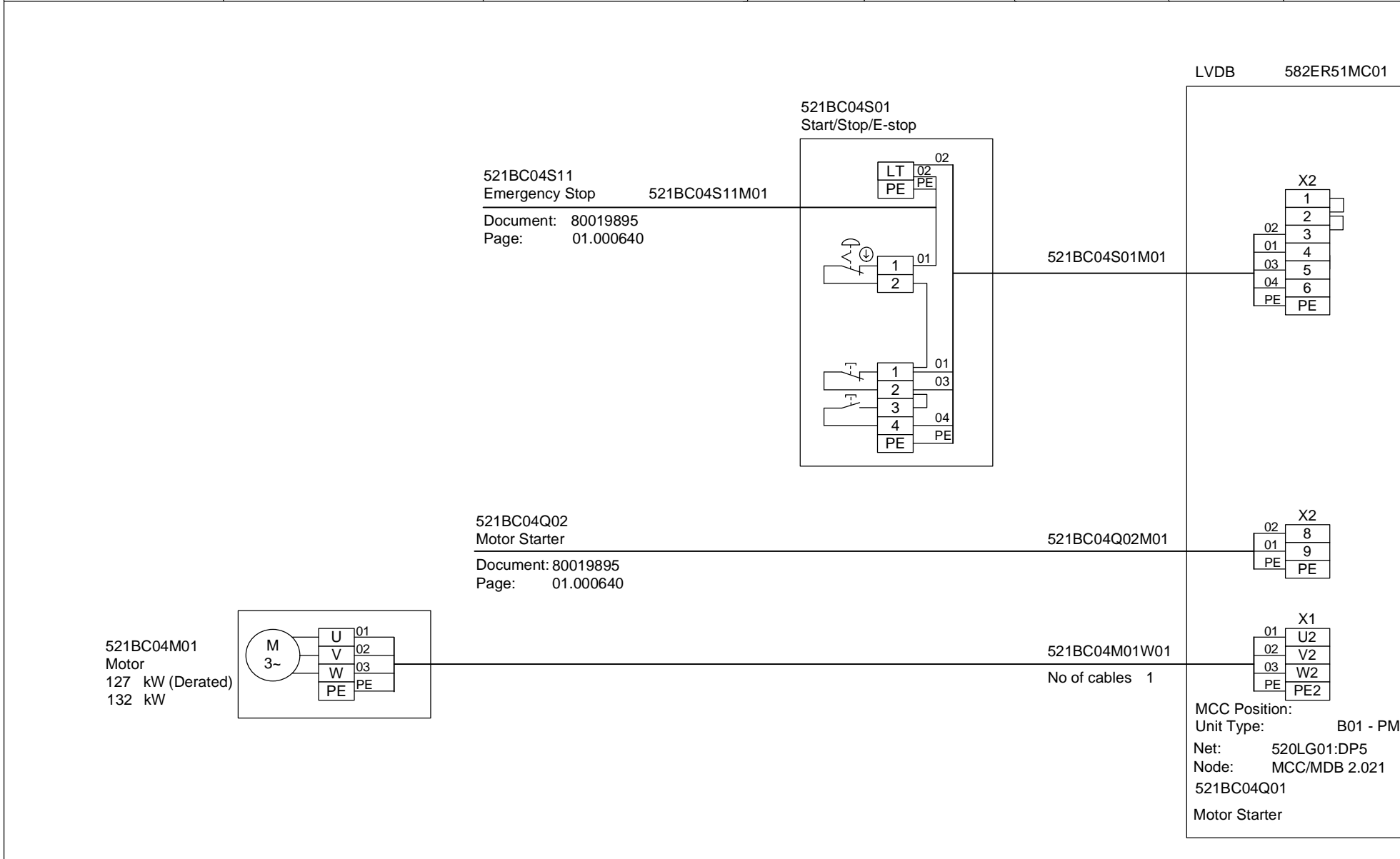

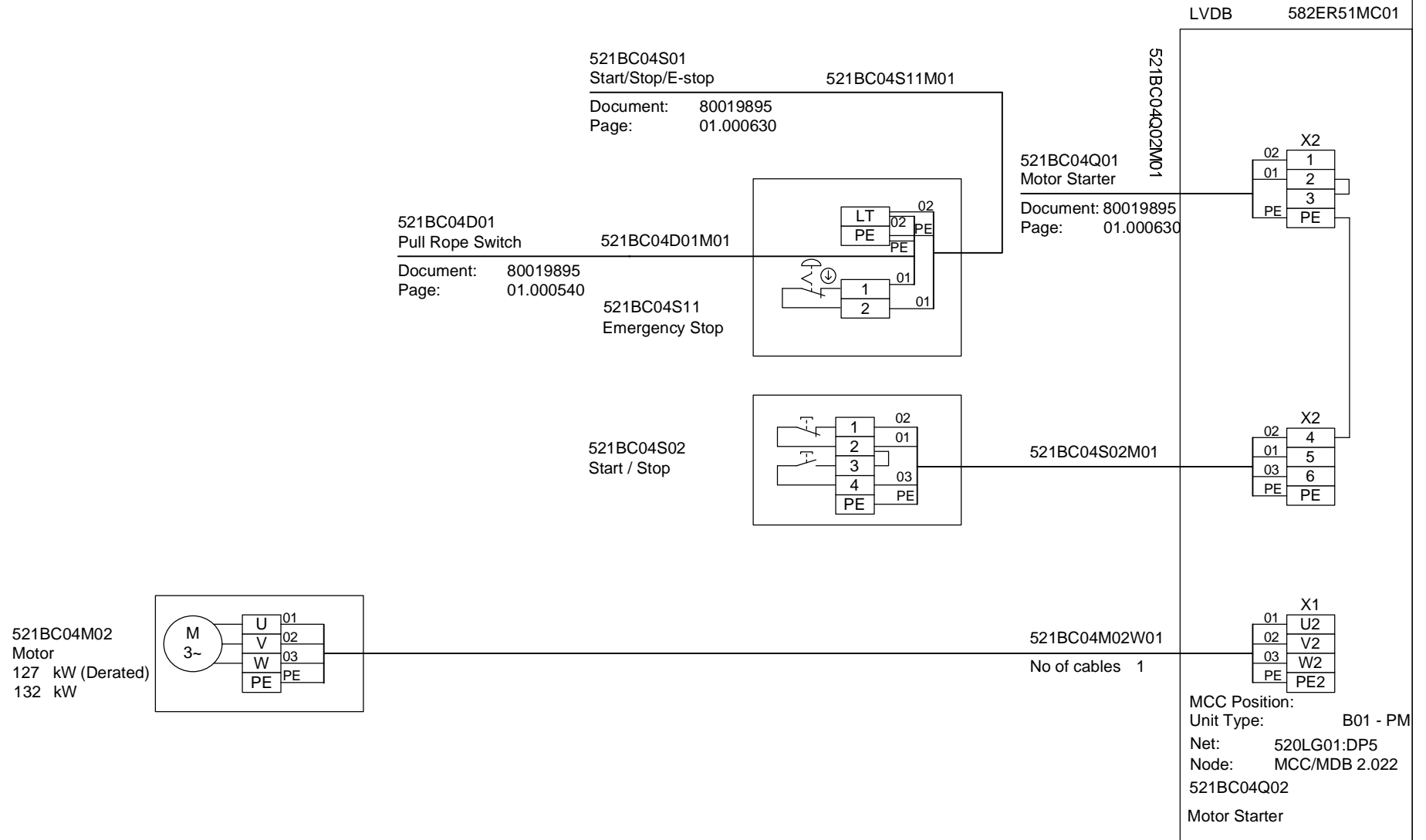

520LG01A02

521JB03A

	Address	Position	Term:
+24 VDC		X05.03.A	04+
Winding Temp. -U	521BC04N21T01	N02.01..10.08	X05.03.A 04
+24 VDC		X05.03.A	05+
Winding Temp. -V	521BC04N22T01	N02.01..10.12	X05.03.A 05
+24 VDC		X05.03.A	06+
Winding Temp. -W	521BC04N23T01	N02.01..10.14	X05.03.A 06

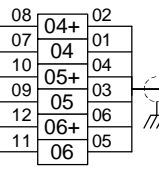

521BC04N21C01

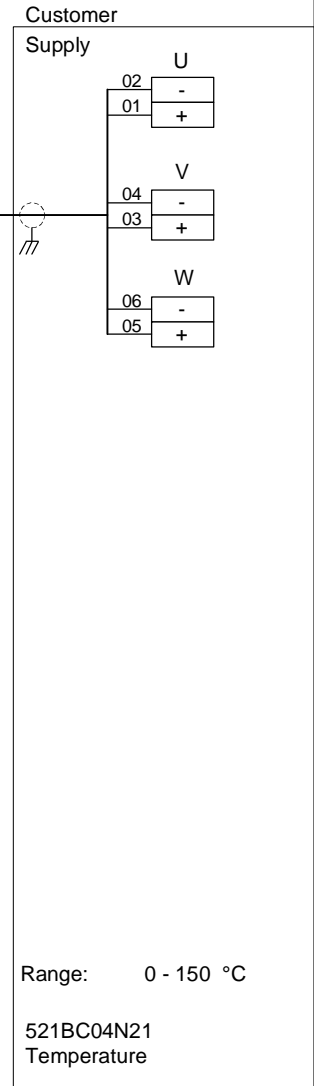

This model needs detailed information from Client on terminals to be connected.

Terminals considered now are tentative

520LG01A02

521JB03A

	Address	Position	Term:
+24 VDC		X05.03.A	07+
Winding Temp. -U	521BC04N24T01	AI N02.01..10.16	X05.03.A 07
+24 VDC		X05.03.A	08+
Winding Temp. -V	521BC04N25T01	AI N02.01..10.18	X05.03.A 08
+24 VDC		X05.03.A	09+
Winding Temp. -W	521BC04N26T01	AI N02.01..11.02	X05.03.A 09

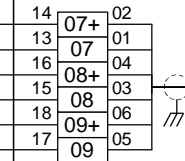

521BC04N24C01

Customer
Supply

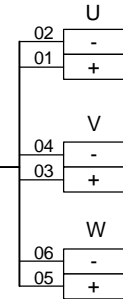

This model needs detailed information from Client on terminals to be connected.

Terminals considered now are tentative

Range: 0 - 150 °C

521BC04N24
Temperature



520LG01A03		521JB05X			
	Address	Position	Term:		
220 VAC		X06.05.A	14L	41	03
Sway Max 1	521BC06D01Z41	DI	N02.01..07.17	X06.05.A	14
Sway Max 2	521BC06D01Z42	DI	N02.01..07.18	X06.05.A	15

Customer
Supply

03	1
01	2
02	3
PE	PE

This model needs detailed information from Client on terminals to be connected.

Terminals considered now are tentative

521BC06D01
Sway Alarm

521BC06S01
Start/Stop/E-stop

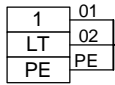

521BC06D02M01

Kiepe
Pull Rope Switch
NTS 002

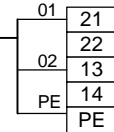

521BC06D02
Pull Rope Switch

Document: 80019895
Page: 01.000690

521BC06D02
 Pull Rope Switch
 Document: 80019895
 Page: 01.000680

521BC06D02M01

521BC06S01
 Start/Stop/E-stop

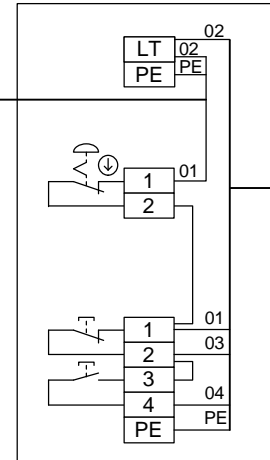

521BC06S01M01

LVDB 582ER51MC01

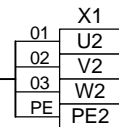
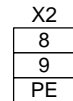
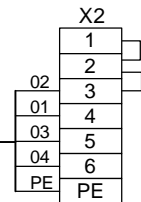

521BC06M01W01

No of cables 1

521BC06M01
 Motor
 72 kW (Derated)
 75 kW

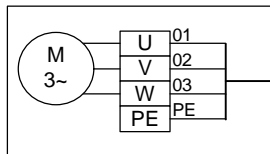

MCC Position:
 Unit Type: B01 - PM
 Net: 520LG01:DP5
 Node: MCC/MDB 2.025
 521BC06Q01 Motor Starter



521BC06M01

Belt Conveyor
 Motor

80019895

01.000690

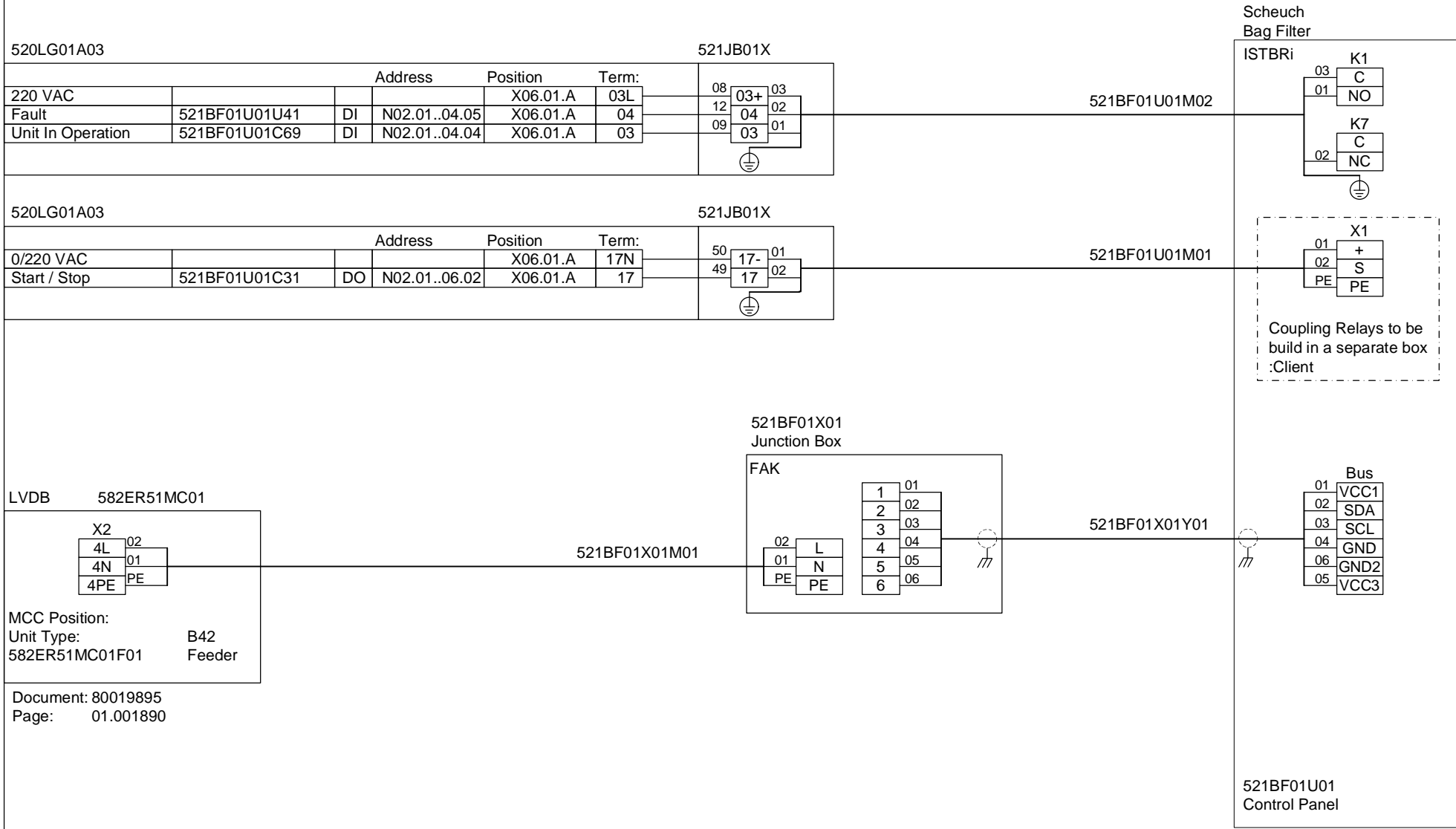

MTS
WC9604

520LG01A11
Network Interface Box Profibus
Document: 80019895
Page: 01.000170

521BW01A01Y01

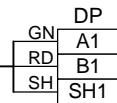

LVDB 582ER51MC01

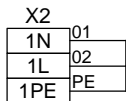

MCC Position:
Unit Type: B42
582ER51MC01F01 Feeder

521BW01A01M01

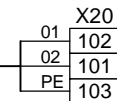

521BW01A01
Control Panel



521BW01A01

Belt Weigher
Control Panel

80019895

01.000710

Tonasa	A Crane/Hoist	Cranes / Hoist	-	9/13/2010 1:16:51 PM	12/22/2011 12:52:36 PM	Customer	A1
--------	---------------	----------------	---	----------------------	------------------------	----------	----

Customer
Supply

LVDB 582ER51MC01

X0	
U2	01
V2	02
W2	03

MCC Position:
Type: B32
521CA01Q01 Power Feeder

521CA01Q01W01

No of cables 1

01	U1
02	V1
03	W1

521CA01A01
Cabinet



521CA01A01

Crane
Cabinet

80019895

01.000720

Tonasa	A LCP B28 Power Feeder	A LCP B28 (3Ph+N+E)	-	11/22/2010 5:00:33 AM	12/22/2011 12:52:36 PM	Customer	A1
--------	------------------------	---------------------	---	-----------------------	------------------------	----------	----

Customer
Supply

LVDB 582ER51MC01

X0	
U2	01
V2	02
W2	03
N2	04
PE2	PE

MCC Position:
Unit Type: B28
521CP01Q01 Power Feeder

521CP01Q01W01

No of cables 1

01	U1
02	V1
03	W1
04	N1
PE	PE1

521CP01A01
Cabinet



521CP01A01

Compressor
Cabinet

80019895

01.000730



520LG01A03

	Address	Position	Term:
220 VAC		X06.01.A	05L
Pressure Switch	521CP01D01P41	X06.01.A	05

521JB01X

521CP01D01M01

Customer Supply

This drawing needs detailed information from Client on terminals to be connected.

Terminals considered now are tentative

521CP01D01
Pressure Switch

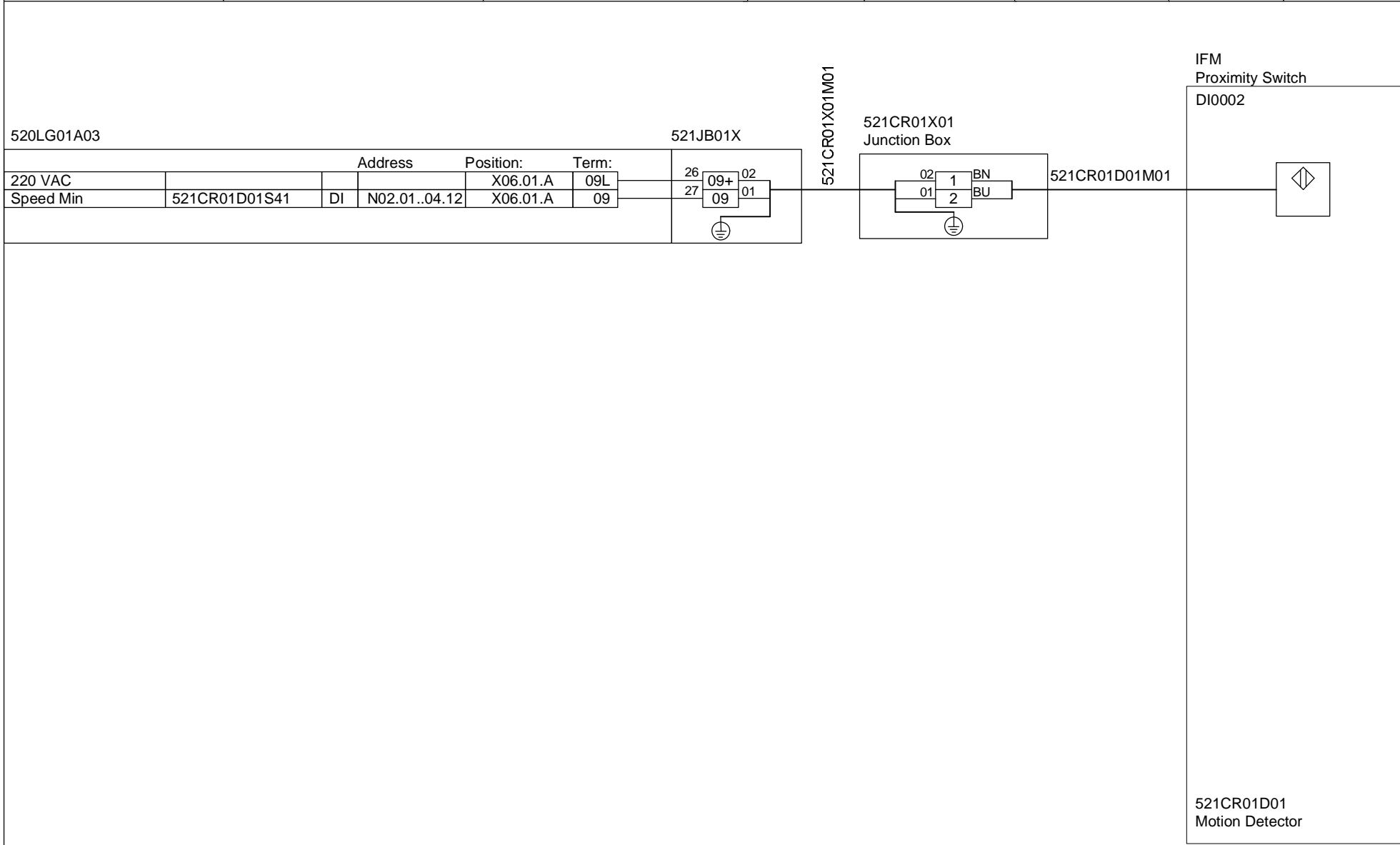

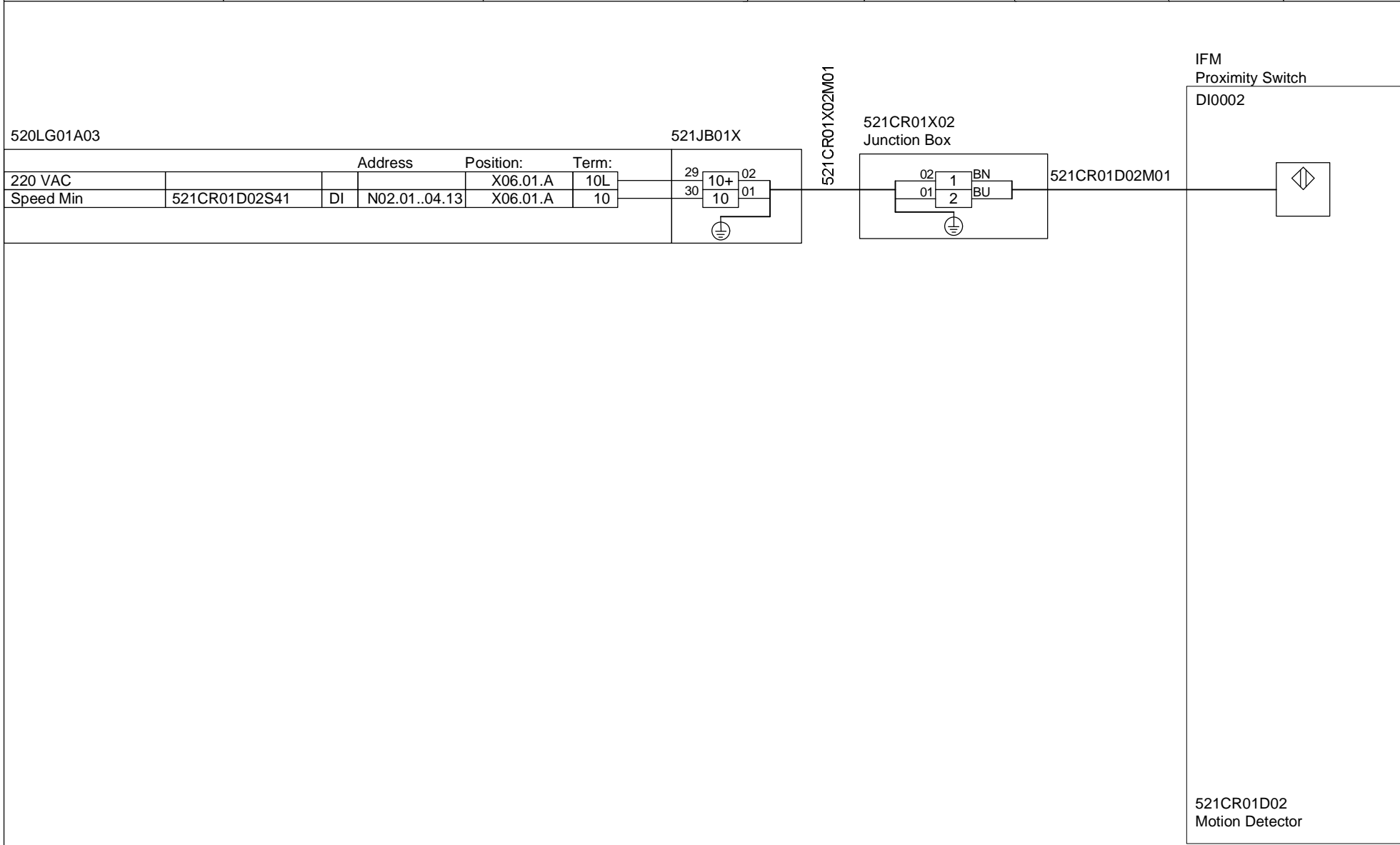

Tonasa	DL Generic (Single-DI)	DL Generic (Single-DI)	-	4/25/2011 7:24:18 AM	12/22/2011 12:52:38 PM	Customer	A1
--------	------------------------	------------------------	---	----------------------	------------------------	----------	----



520LG01A03

	Address	Position	Term:
220 VAC		X06.01.A	11L
Safety Switch Aux-1	521CR01D03Z41	DI	N02.01..04.14 X06.01.A 11

521JB01X

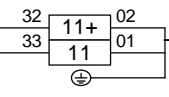

521CR01D03M01

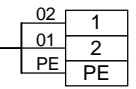

Customer Supply

This drawing needs detailed information from Client on terminals to be connected.

Terminals considered now are tentative

521CR01D03 Switch

Tonasa	DL Generic (Single-DI)	DL Generic (Single-DI)	VCI-IN	4/25/2011 7:25:22 AM	12/26/2011 6:54:01 AM	Customer	A1
--------	------------------------	------------------------	--------	----------------------	-----------------------	----------	----



520LG01A03

	Address	Position	Term:
220 VAC		X06.01.A	12L
Safety Switch Aux-2	521CR01D04Z41	X06.01.A	12

521JB01X

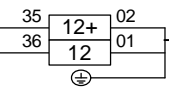

521CR01D04M01

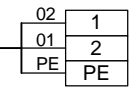

Customer
Supply

521CR01D04
Switch

This drawing needs detailed information from Client on terminals to be connected.

Terminals considered now are tentative

LVDB 582ER51MC01

521CR01S07
Start/Stop/E-stop

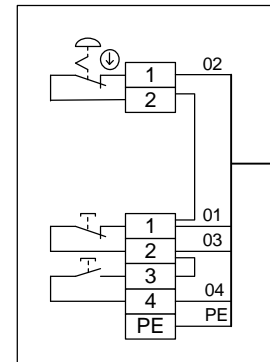

521CR01S07M01

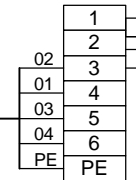

521CR01E01
Heating Element
kW (Derated)
kW

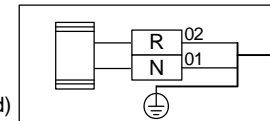

521CR01E01M01

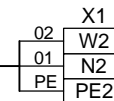

Position:
Unit Conn. Type: B22
Net: 520LG01:DP5
Node: MCC/MDB 2.028
521CR01Q07 Motor Starter



521CR01E01

Crusher
Heating Element -1

80019895

01.000790

LVDB 582ER51MC01

521CR01S08
Start/Stop/E-stop

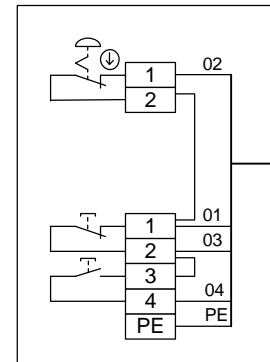

521CR01S08M01

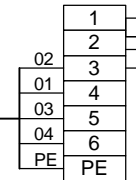

521CR01E02
Heating Element
kW (Derated)
kW

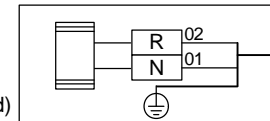

521CR01E02M01

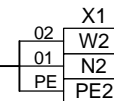

Position:
Unit Conn. Type: B22
Net: 520LG01:DP5
Node: MCC/MDB 2.029
521CR01Q08 Motor Starter



521CR01E02

Crusher
Heating Element -2

80019895

01.000800

Tonasa	R Slip Ring Light	R Slip Ring Light	-	11/30/2010 4:35:15 AM	12/22/2011 12:52:40 PM	Customer	A1
--------	-------------------	-------------------	---	-----------------------	------------------------	----------	----

LVDB 582ER51MC01

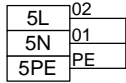

MCC Position:
Unit Type: B42
582ER51MC01F01 Feeder

521CR01LX1M01

ABB
Slip Ring Light

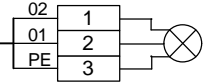

521CR01LX1
Slip Ring Light



521CR01LX1

Lighting
Slip Ring Light

80019895

01.000810

Tonasa	R Slip Ring Light	R Slip Ring Light	-	11/30/2010 4:35:38 AM	12/22/2011 12:52:41 PM	Customer	A1
--------	-------------------	-------------------	---	-----------------------	------------------------	----------	----

LVDB 582ER51MC01

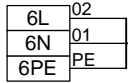

MCC Position:
Unit Type: B42
582ER51MC01F01 Feeder

521CR01LX2M01

ABB
Slip Ring Light

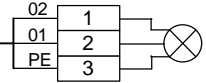

521CR01LX2
Slip Ring Light



521CR01LX2

Lighting
Slip Ring Light

80019895

01.000820

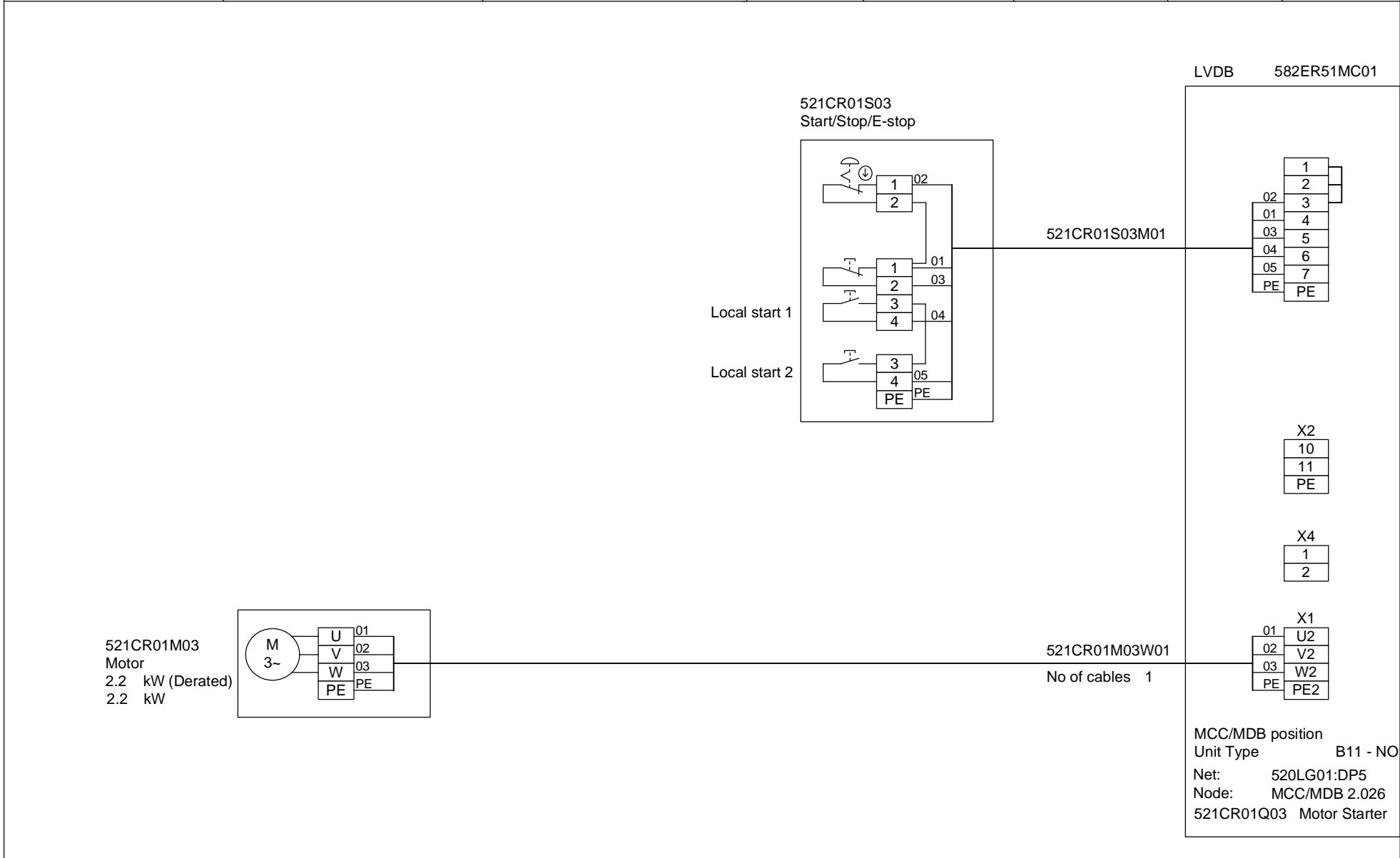

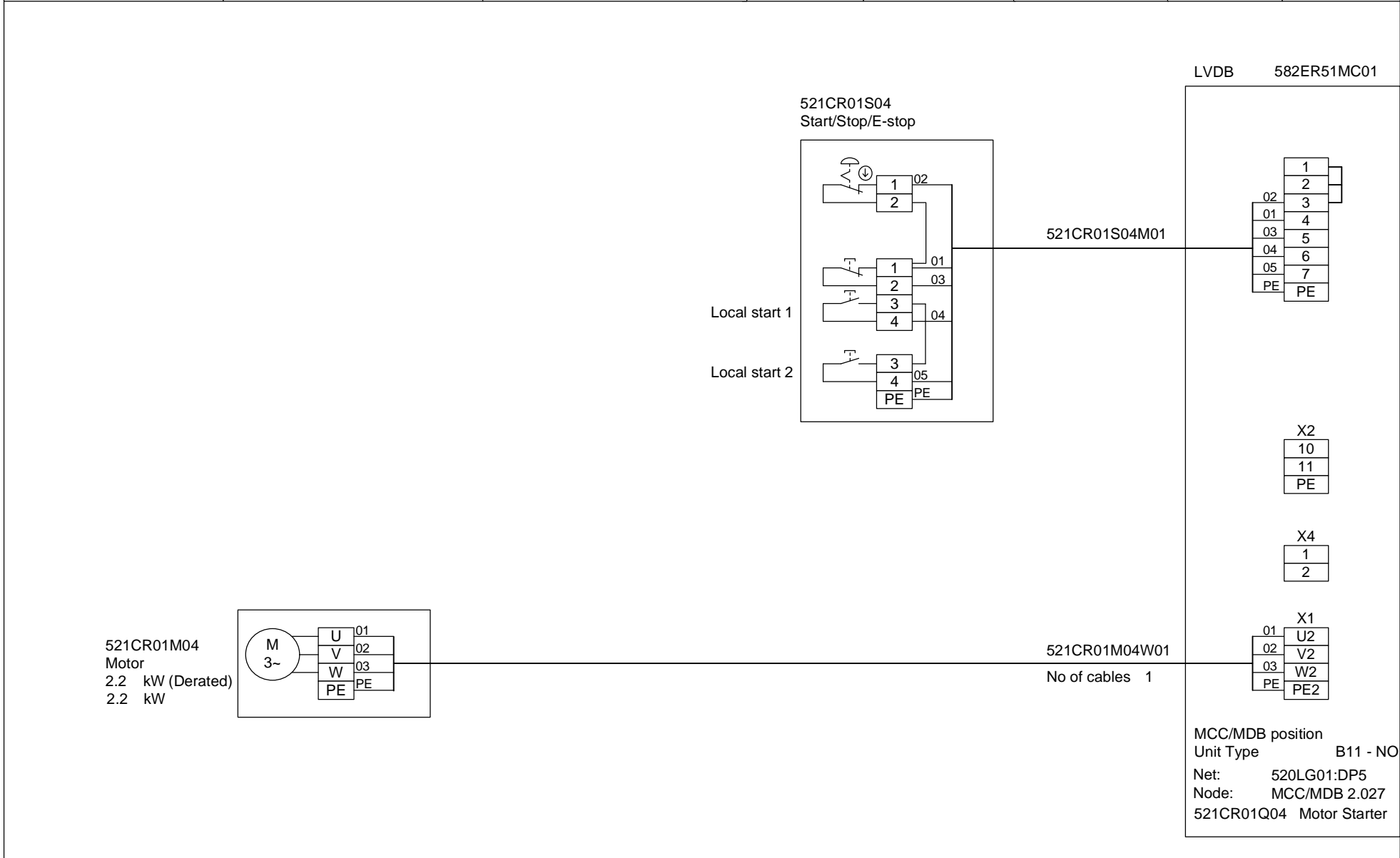

520LG01A02

521JB01A

	Address	Position:	Term:
+24 VDC		X05.01.A	09+
Temperature	521CR01N11T01	AI N02.01..05.02	X05.01.A 09

Customer Supply

521CR01B01
Sensor

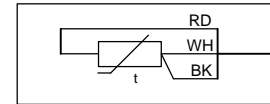

521CR01N11C01

521CR01B01C01

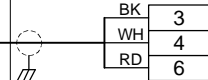
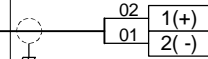

Range 0 - 130 °C

521CR01N11

Temperature



521CR01N11 Crusher Mot 1, Rotor Bearing 1
Temperature

80019895

01.000850

520LG01A02

521JB01A

	Address	Position:	Term:
+24 VDC		X05.01.A	10+
Temperature	521CR01N12T01	AI N02.01..05.04	X05.01.A 10

Customer Supply

521CR01B02 Sensor

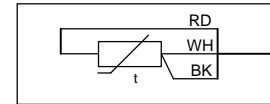

521CR01N12C01

521CR01B02C01

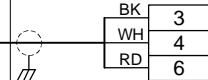
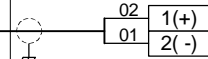

Range 0 - 130 °C

521CR01N12

Temperature



521CR01N12 Crusher Mot 1, Rotor Bearing 2 Temperature

80019895

01.000860

520LG01A02

521JB01A

	Address	Position:	Term:
+24 VDC		X05.01.A	11+
Temperature	521CR01N13T01	AI N02.01..05.06	X05.01.A 11

Customer Supply

521CR01B03
Sensor

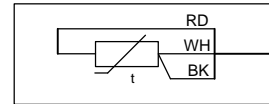

521CR01N13C01

521CR01B03C01

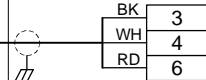
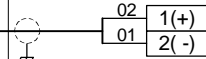

Range 0 - 110 °C

521CR01N13

Temperature



521CR01N13 Crusher Mot 1, Jack Shaft Bearing 1
Temperature

80019895

01.000870

520LG01A02

521JB01A

	Address	Position:	Term:
+24 VDC		X05.01.A	12+
Temperature	521CR01N14T01	AI N02.01..05.08	X05.01.A 12

Customer Supply

521CR01B04 Sensor

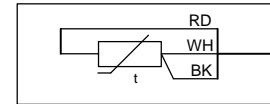

521CR01N14C01

521CR01B04C01

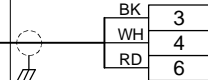
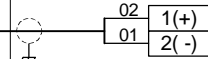

Range 0 - 110 °C

521CR01N14

Temperature



521CR01N14 Crusher Mot 1, Jack Shaft Bearing 2 Temperature

80019895

01.000880

520LG01A02

521JB01A

Customer
Supply

	Address	Position:	Term:
+24 VDC		X05.01.A	13+
Temperature	521CR01N15T01	AI N02.01..05.12	X05.01.A 13

521CR01B05
Sensor

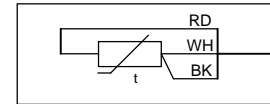

521CR01N15C01

521CR01B05C01

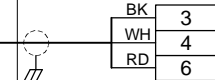
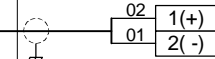

Range 0 - 130 °C

521CR01N15

Temperature



521CR01N15 Crusher Mot 2, Rotor Bearing 1
Temperature

80019895

01.000890

520LG01A02

521JB01A

	Address	Position:	Term:
+24 VDC		X05.01.A	14+
Temperature	521CR01N16T01	AI N02.01..05.14	X05.01.A 14

Customer Supply

521CR01B06 Sensor

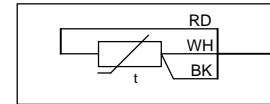

521CR01N16C01

521CR01B06C01

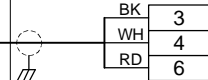
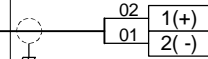

Range 0 - 130 °C

521CR01N16

Temperature



521CR01N16 Crusher Mot 2, Rotor Bearing 2 Temperature

80019895

01.000900

520LG01A02

521JB02A

Customer
Supply

	Address	Position:	Term:
+24 VDC		X05.02.A	01+
Temperature	521CR01N17T01	AI N02.01..07.02	X05.02.A 01

521CR01B07
Sensor

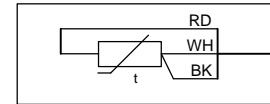

521CR01N17C01

521CR01B07C01

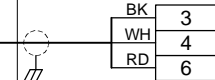
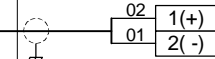

Range 0 - 110 °C

521CR01N17

Temperature



521CR01N17 Crusher Mot 2, Jack Shaft Bearing 1
Temperature

80019895

01.000910

520LG01A02

521JB02A

	Address	Position:	Term:
+24 VDC		X05.02.A	02+
Temperature	521CR01N18T01	AI N02.01..07.04	X05.02.A 02

Customer Supply

521CR01B08 Sensor

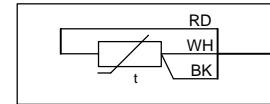

521CR01N18C01

521CR01B08C01

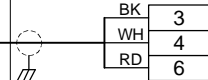
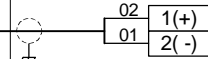

Range 0 - 110 °C

521CR01N18

Temperature



521CR01N18 Crusher Mot 2, Jack Shaft Bearing 2 Temperature

80019895

01.000920

520LG01A02

521JB02A

	Address	Position:	Term:			
+24 VDC			X05.02.A	03+	06	02
Temp. DE Bearing	521CR01N21T01	AI	N02.01..07.06	X05.02.A	05	01
+24 VDC			X05.02.A	04+	08	04
Temp. NDE Bearing	521CR01N22T01	AI	N02.01..07.08	X05.02.A	07	03
+24 VDC			X05.02.A	05+	10	06
Temp. Winding U	521CR01N23T01	AI	N02.01..07.12	X05.02.A	09	05
+24 VDC			X05.02.A	06+	12	08
Temp. Winding V	521CR01N24T01	AI	N02.01..07.14	X05.02.A	11	07
+24 VDC			X05.02.A	07+	14	10
Temp. Winding W	521CR01N25T01	AI	N02.01..07.16	X05.02.A	13	09

Customer
Supply

521CR01N21C01

Winding U

02	1+
01	2-

Winding V

04	1+
03	2-

Winding W

06	1+
05	2-

DE Bearing

08	1+
07	2-

NDE Bearing

10	1+
09	2-

This model needs detailed information from Client on terminals to be connected.

Terminals considered now are tentative

Range: 0 - 130 °C

521CR01N21
Temperature

520LG01A02

521JB02A

	Address	Position:	Term:	
+24 VDC			X05.02.A 08+	16 08+ 02
Temp. DE Bearing	521CR01N26T01	AI	N02.01..07.18 X05.02.A 08	15 08 01
+24 VDC			X05.02.A 09+	18 09+ 04
Temp. NDE Bearing	521CR01N27T01	AI	N02.01..08.02 X05.02.A 09	17 09 03
+24 VDC			X05.02.A 10+	20 10+ 06
Temp. Winding U	521CR01N28T01	AI	N02.01..08.04 X05.02.A 10	19 10 05
+24 VDC			X05.02.A 11+	22 11+ 08
Temp. Winding V	521CR01N29T01	AI	N02.01..08.06 X05.02.A 11	21 11 07
+24 VDC			X05.02.A 12+	24 12+ 10
Temp. Winding W	521CR01N30T01	AI	N02.01..08.08 X05.02.A 12	23 12 09

521CR01N26C01

Customer Supply

Winding U

02	1+
01	2-

Winding V

04	1+
03	2-

Winding W

06	1+
05	2-

DE Bearing

08	1+
07	2-

NDE Bearing

10	1+
09	2-

This model needs detailed information from Client on terminals to be connected.

Terminals considered now are tentative

Range: 0 - 130 °C

521CR01N26
Temperature

521CR01S01
Start/Stop/E-stop

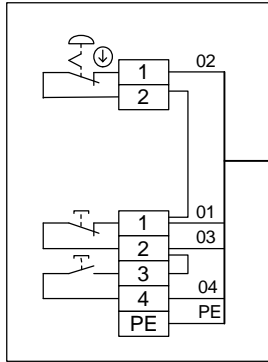

MVDB 582ER51

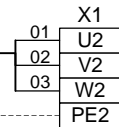
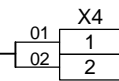
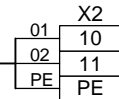
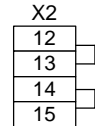
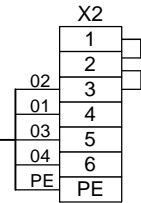

521CR01R01
Rotor Starter

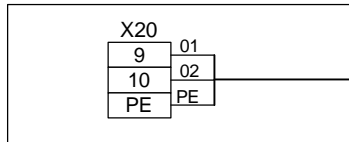

Document: 80019895
Page: 01.000990

521CR01R01
Rotor Starter

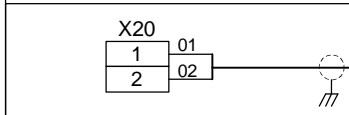

Document: 80019895
Page: 01.000990

521CR01R01
Rotor Starter

Document: 80019895
Page: 01.000990

521CR01R01H01

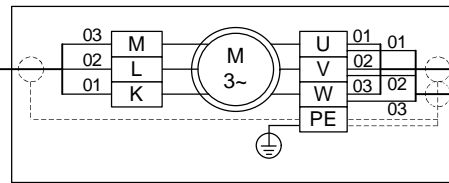

521CR01M01
Motor
1200 kW

521CR01M01H01

No of cables 1

521CR01C01
Capacitor Bank

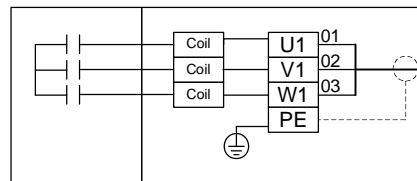

521CR01C01H01

No of cables 1

MCC Position:
Unit Type: C01 NO
Net: 520LG01:DP3
Node: Field Device.042
521CR01Q01
Power Feeder



521CR01Q01

Crusher
Power Feeder

80019895

01.000950

MVDB 582ER51

582ER51LV01Q01
Power Feeder

521CR01Q01Y01

Document: 80019895
Page: 01.001860

X3	
GN	1
RD	2
SH	SH1

521CR01Q02
Power Feeder

521CR01Q02Y01

Document: 80019895
Page: 01.000970

X3	
GN	1.1
RD	2.1
SH	SH2

MCC Position:
Unit Type: C01 NO
Net: 520LG01:DP3
Node: Field Device.042
521CR01Q01
Power Feeder



521CR01Q01

Crusher
Power Feeder

80019895

01.000960

521CR01S02
Start/Stop/E-stop

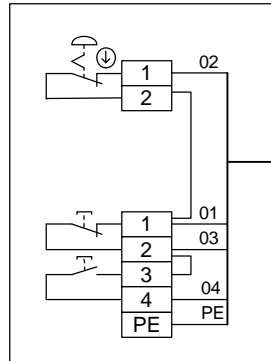

MVDB 582ER51

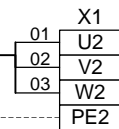
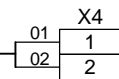
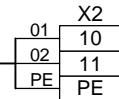
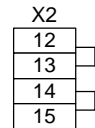
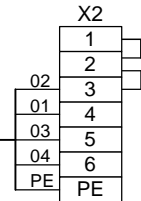

MCC Position:
Unit Type: C01 NO
Net: 520LG01:DP3
Node: Field Device.043
521CR01Q02
Power Feeder

521CR01R02
Rotor Starter

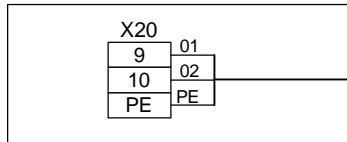

Document: 80019895
Page: 01.001010

521CR01R02
Rotor Starter

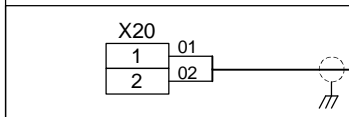

Document: 80019895
Page: 01.001010

521CR01R02
Rotor Starter

Document: 80019895
Page: 01.001010

521CR01R02H01

521CR01M02
Motor
1200 kW

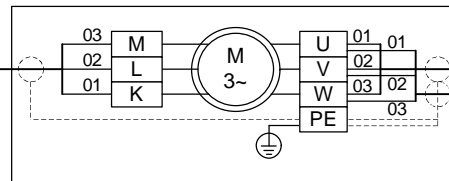

521CR01M02H01

No of cables 1

521CR01C02
Capacitor Bank

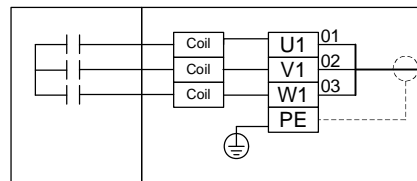

521CR01C02H01

No of cables 1



521CR01Q02

Crusher
Power Feeder

80019895

01.000970

MVDB 582ER51

521CR01Q01
Power Feeder

521CR01Q02Y01

Document: 80019895
Page: 01.000950

X3	
GN	1
RD	2
SH	SH1

521AF01U01
Frequency Converter

521AF01U01Y01

Document: 80019895
Page: 01.000260

X3	
GN	1.1
RD	2.1
SH	SH2

MCC Position:
Unit Type: C01 NO
Net: 520LG01:DP3
Node: Field Device.043
521CR01Q02
Power Feeder



521CR01Q02

Crusher
Power Feeder

80019895

01.000980

Tonasa	R Rotor Starter MKS	R Rotor Starter MKS-1	-	10/13/2010 5:15:05 AM	12/22/2011 12:52:49 PM	Customer	A1
--------	---------------------	-----------------------	---	-----------------------	------------------------	----------	----

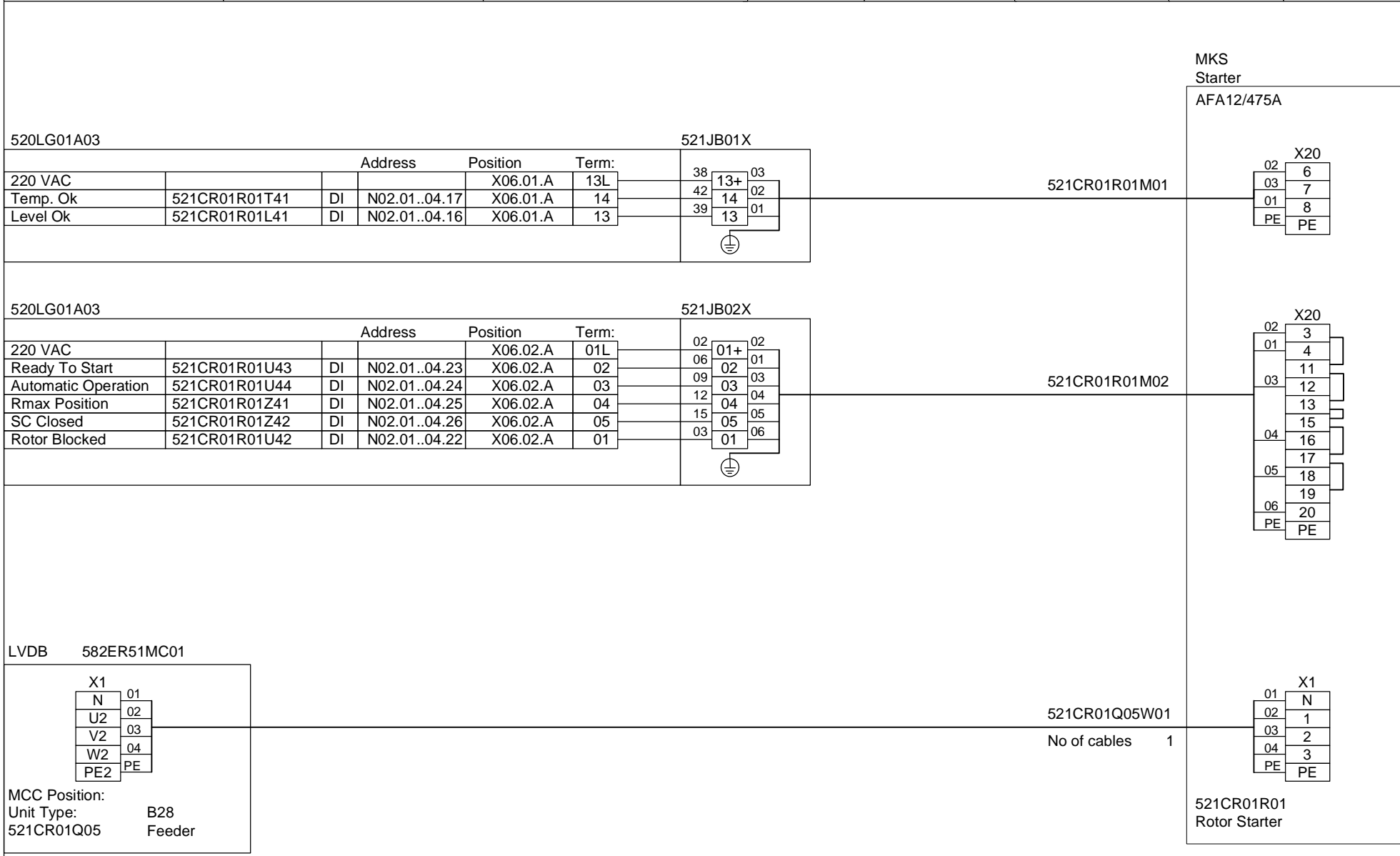

FLSMIDTH	521CR01R01	Crusher Rotor Starter	80019895	01.000990
-----------------	------------	-----------------------	----------	-----------

MKS
Starter
AFA12/475A

521CR01Q01
Power Feeder
Document: 80019895
Page: 01.000950

521CR01R01M03

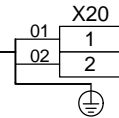

582ER51MC01F01
Feeder
Document: 80019895
Page: 01.001890

521CR01R01M04

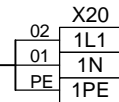

521CR01M01
Motor
Document: 80019895
Page: 01.000950

521CR01R01H01

No of cables 1

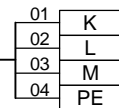

521CR01R01
Rotor Starter



521CR01R01

Crusher
Rotor Starter

80019895

01.001000

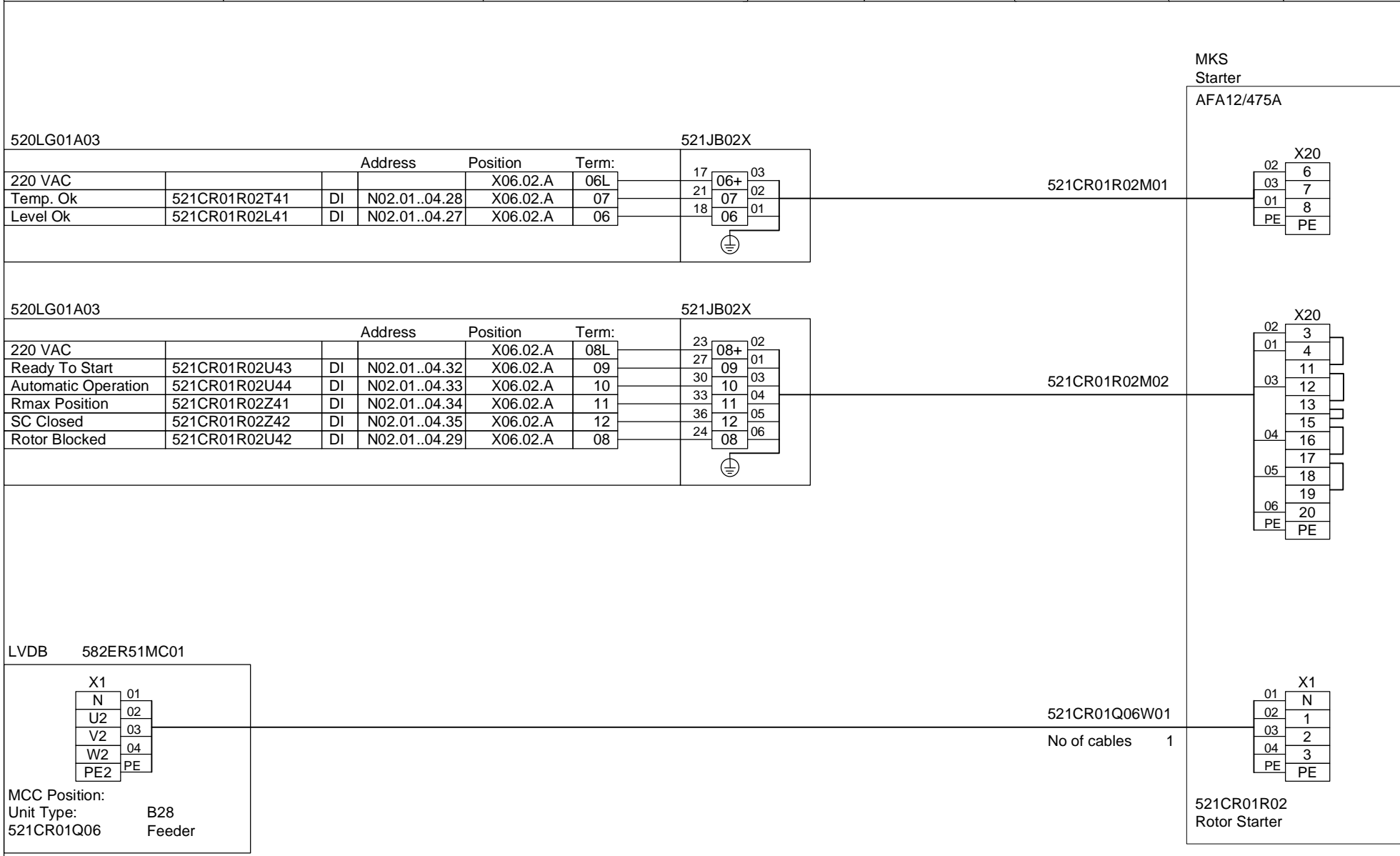

MKS
Starter
AFA12/475A

521CR01Q02
Power Feeder
Document: 80019895
Page: 01.000970

521CR01R02M03

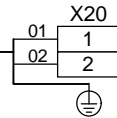

582ER51MC01F01
Feeder
Document: 80019895
Page: 01.001890

521CR01R02M04

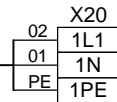

521CR01M02
Motor
Document: 80019895
Page: 01.000970

521CR01R02H01

No of cables 1

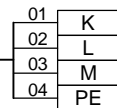

521CR01R02
Rotor Starter



521CR01R02

Crusher
Rotor Starter

80019895

01.001020

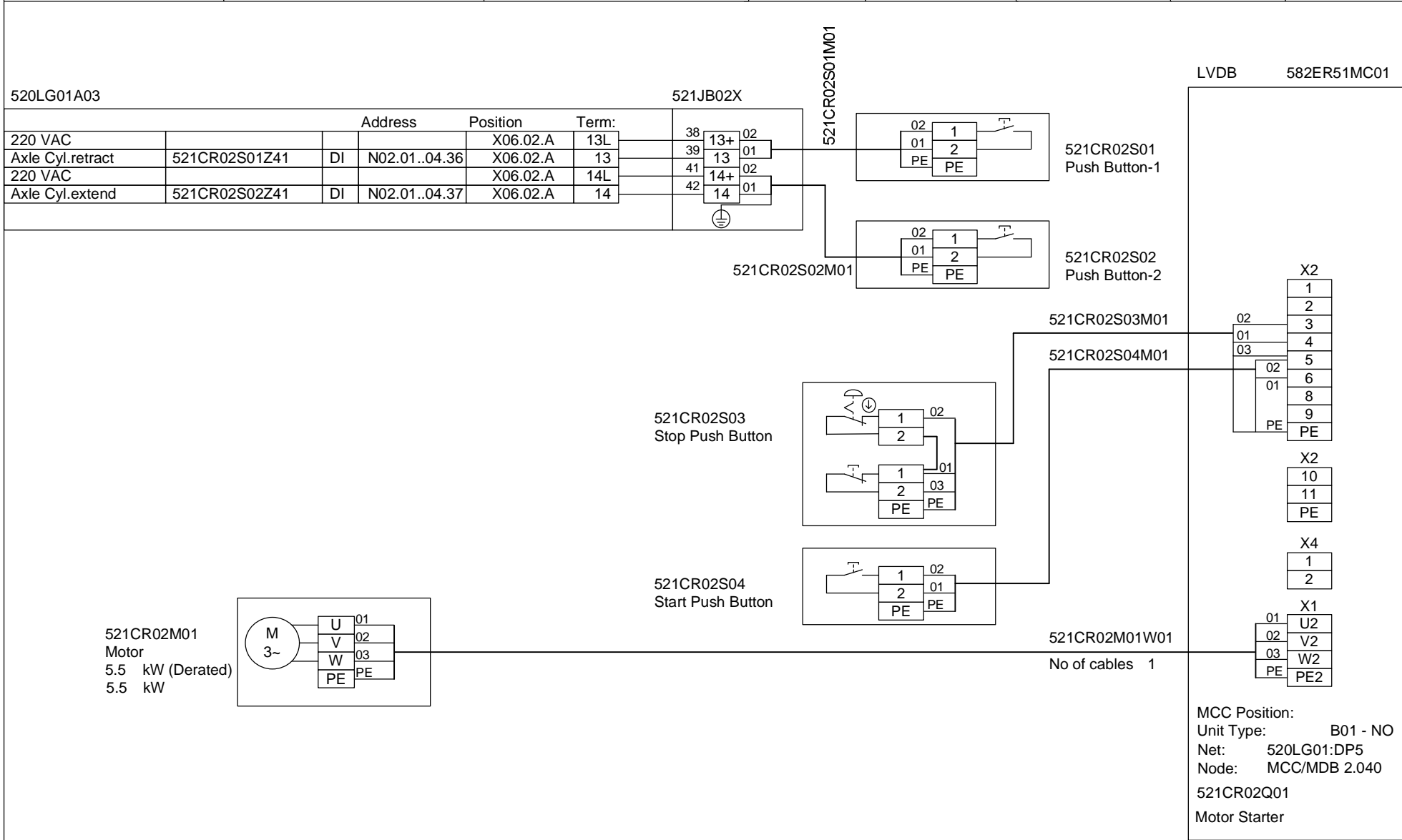

520LG01A03

521JB01X

	Address	Position	Term:
0/220 VAC		X06.01.A	18N
Oil Circuit Valve Y1	521CR02Y01C31	DO	N02.01..06.03 X06.01.A 18

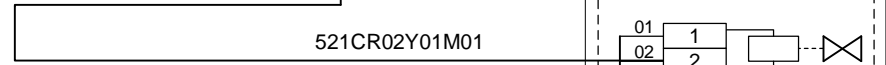
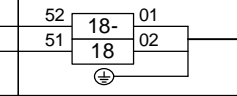

Customer

Supply

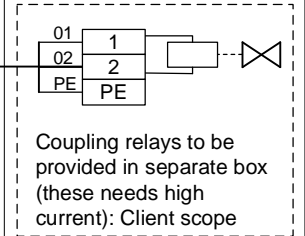

(0.18kW Power Cons.)

521CR02Y01
Solenoid Valve



521CR02Y01

Hammer Axle Extraction Device
Solenoid Valve

80019895

01.001040

Tonasa	DL Generic (1 DO- S/V) 521CR02	DL Generic (1 DO- S/V) 521CR02	-	9/15/2011 5:54:23 AM	12/22/2011 12:52:52 PM	Customer	A1
--------	--------------------------------	--------------------------------	---	----------------------	------------------------	----------	----

520LG01A03

521JB01X

	Address	Position	Term:
0/220 VAC		X06.01.A	19N
Oil Circuit Valve Y1	521CR02Y02C31	DO	N02.01..06.04 X06.01.A 19

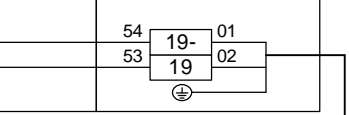

Customer

Supply

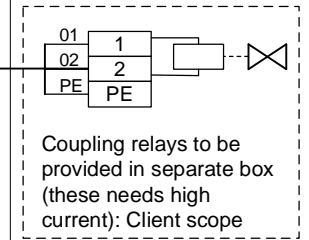

Coupling relays to be provided in separate box (these needs high current): Client scope

(0.18kW Power Cons.)

521CR02Y02 Solenoid Valve

	521CR02Y02	Hammer Axle Extraction Device Solenoid Valve	80019895	01.001050
--	------------	--	----------	-----------

Tonasa	A LCP B28 Power Feeder	A LCP B28 (3Ph+N+E)	-	9/13/2010 12:47:51 PM	12/22/2011 12:52:53 PM	Customer	A1
--------	------------------------	---------------------	---	-----------------------	------------------------	----------	----

Customer
Supply

LVDB 582ER51MC01

X0	
U2	01
V2	02
W2	03
N2	04
PE2	PE

MCC Position:
Unit Type: B28
521CR03Q01 Power Feeder

521CR03Q01W01

No of cables 1

01	U1
02	V1
03	W1
04	N1
PE	PE1

521CR03A01
Cabinet



521CR03A01

Grate Bask. Extract. carriage
Cabinet

80019895

01.001060

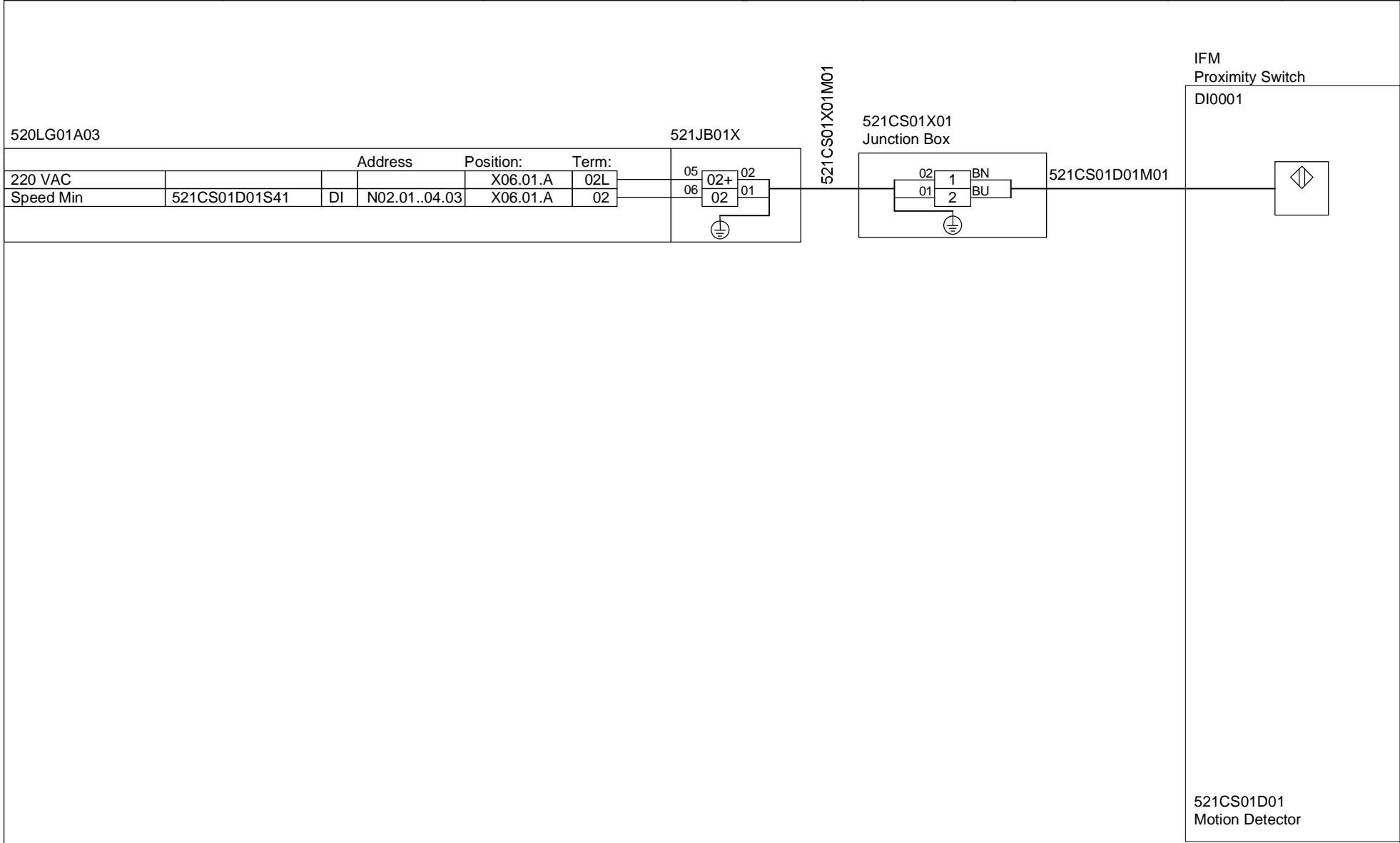

LVDB 582ER51MC01

521CS01S01
Start/Stop/E-stop

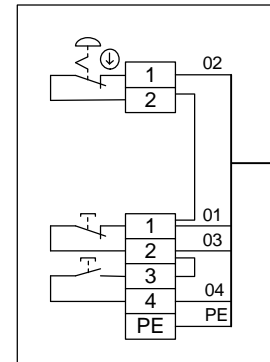

521CS01S01M01

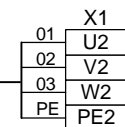
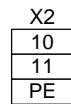
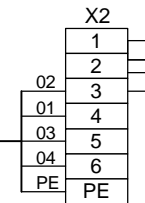

521CS01M01W01

No of cables 1

521CS01M01
Motor
3 kW (Derated)
3 kW

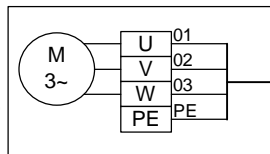

MCC Position:
Unit Type: B01 - NO
Net: 520LG01:DP5
Node: MCC/MDB 2.030
521CS01Q01
Motor Starter



521CS01M01

Spillage Conveyor
Motor

80019895

01.001080

521DV01Q01
Motor Starter

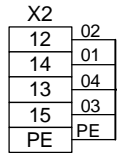

521DV01X01M01

521DV01X01
Junction Box

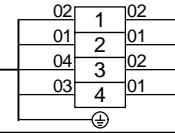

521DV01D01M01

521DV01D02M01

Ebro
Micro Switch

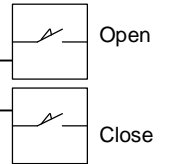

Document: 80019895
Page: 01.001100

521DV01D01
Limit Switch

LVDB 582ER51MC01

521DV01S01
Start/Stop/E-stop

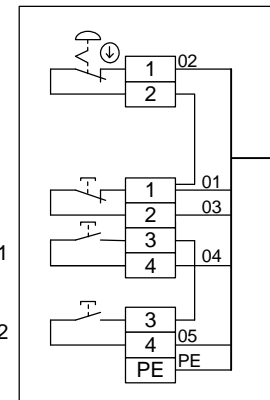

Local start 1

Local start 2

521DV01S01M01

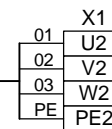
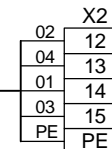
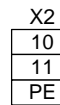
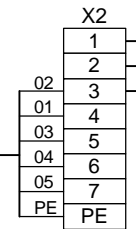

521DV01X01
Junction Box

521DV01X01M01

Document: 80019895
Page: 01.001090

521DV01M01
Motor
3 kW (Derated)
3 kW

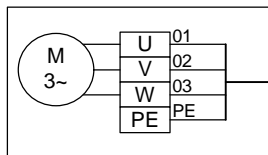

521DV01M01W01

No of cables 1

MCC/MDB position
Unit Type B13 - NO
Net: 520LG01:DP5
Node: MCC/MDB 2.031
521DV01Q01 Motor Starter



520LG01A03		521JB01X			
	Address	Position	Term:		
220 VAC		X06.01.A	06L	17	06+
Speed Min	521FN01D01S41	X06.01.A	06	18	06

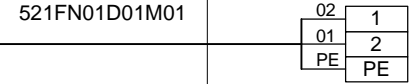

This drawing needs detailed information from Client on terminals to be connected.

Terminals considered now are tentative

521FN01D01
Switch

LVDB 582ER51MC01

521FN01S01
Start/Stop/E-stop

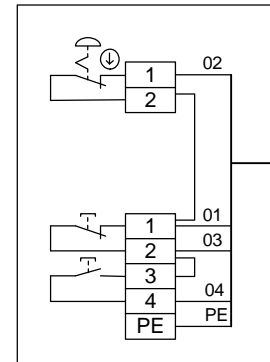

521FN01S01M01

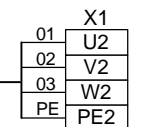
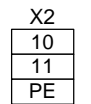
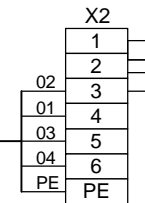

521FN01M01W01

No of cables 1

521FN01M01
Motor
127 kW (Derated)
132 kW

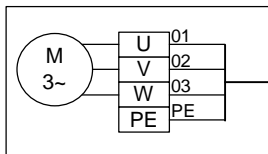

MCC Position:
Unit Type: B01 - PM
Net: 520LG01:DP5
Node: MCC/MDB 2.032
521FN01Q01
Motor Starter



521FN01M01

Filter Fan
Motor

80019895

01.001120

520LG01A02

	Address	Position	Term:
+24 VDC		X05.01.A	02+
Temperature	521FN01N11T01	AI N02.01..04.04	X05.01.A 02

521JB01A

521FN01B01
Sensor

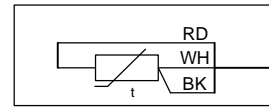

PT100 RTD

521FN01N11C01

Customer
Supply

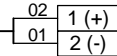

521FN01B01C01

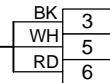

Range: 0 - 130 °C

521FN01N11
Temperature



521FN01N11

Filter Fan Bearing A
Temperature

80019895

01.001130

520LG01A02

	Address	Position	Term:
+24 VDC		X05.01.A	03+
Temperature	521FN01N12T01	AI N02.01..04.06	X05.01.A 03

521JB01A

521FN01B02
Sensor

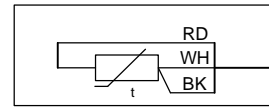

PT100 RTD

521FN01N12C01

Customer
Supply

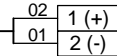

521FN01B02C01

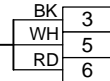

Range: 0 - 130 °C

521FN01N12
Temperature



521FN01N12

Filter Fan Bearing B
Temperature

80019895

01.001140

520LG01A02

521JB01A

	Address	Position	Term:
+24 VDC		X05.01.A	04+
Winding Temp. -U	521FN01N21T01	AI N02.01..04.08	X05.01.A 04
+24 VDC		X05.01.A	05+
Winding Temp. -V	521FN01N22T01	AI N02.01..04.12	X05.01.A 05
+24 VDC		X05.01.A	06+
Winding Temp. -W	521FN01N23T01	AI N02.01..04.14	X05.01.A 06

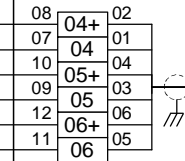

521FN01N21C01

Customer

Supply

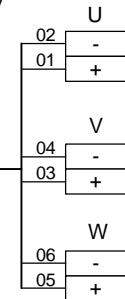

This model needs detailed information from Client on terminals to be connected.

Terminals considered now are tentative

Range: 0 - 150 °C

521FN01N21
Temperature

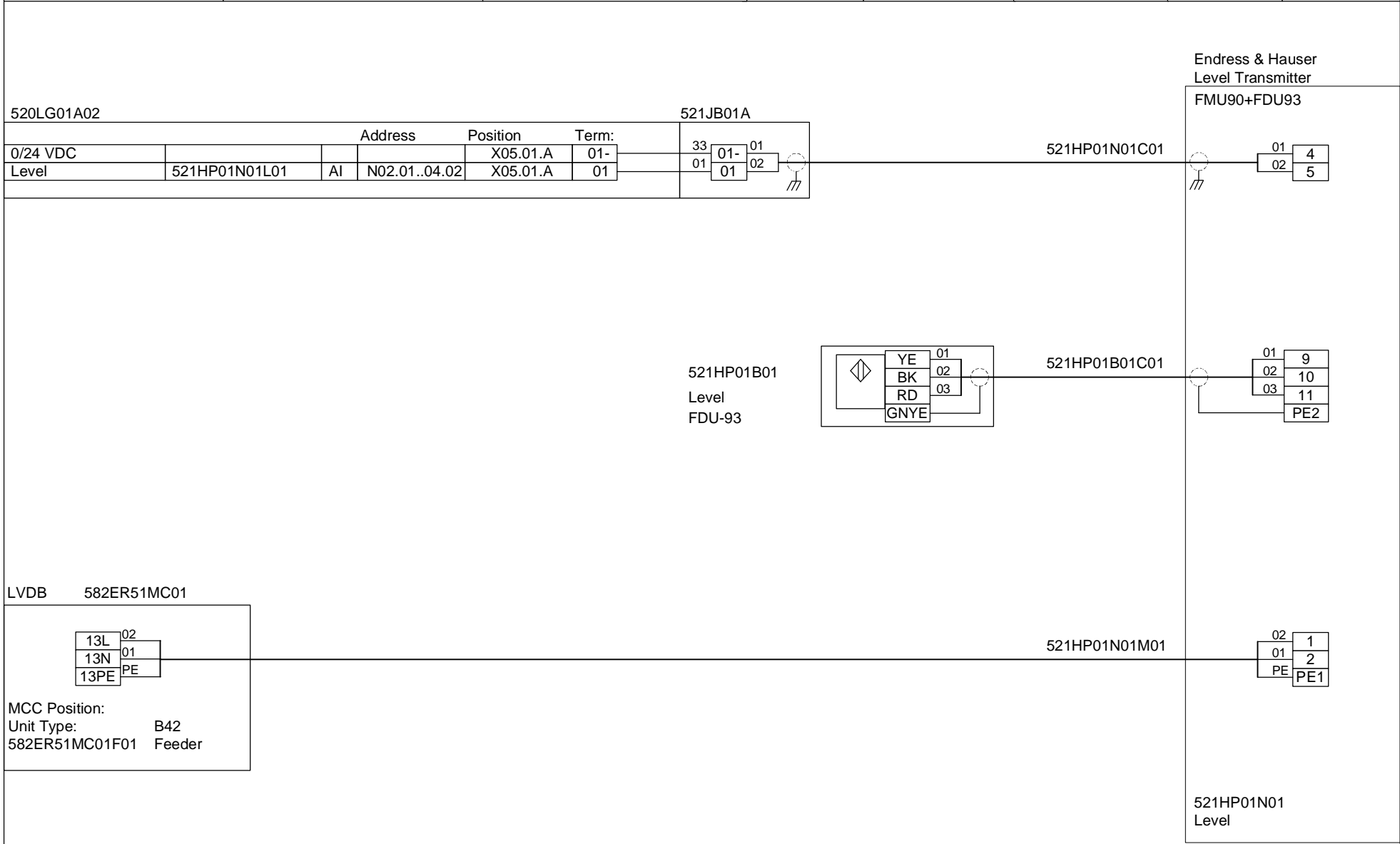

521JB01A
Junction Box

Block	Term:	Signal:	Component:
01	X05.01.A 01	521HP01N01L01	521HP01N01
02	X05.01.A 01+	.	.
33	X05.01.A 01-	0/24 VDC	521HP01N01
03	X05.01.A 02	521FN01N11T01	521FN01N11
04	X05.01.A 02+	+24 VDC	521FN01N11
34	X05.01.A 02-	.	.
05	X05.01.A 03	521FN01N12T01	521FN01N12
06	X05.01.A 03+	+24 VDC	521FN01N12
35	X05.01.A 03-	.	.
07	X05.01.A 04	521FN01N21T01	521FN01N21
08	X05.01.A 04+	+24 VDC	521FN01N21
36	X05.01.A 04-	.	.
09	X05.01.A 05	521FN01N22T01	521FN01N22
10	X05.01.A 05+	+24 VDC	521FN01N22
37	X05.01.A 05-	.	.
11	X05.01.A 06	521FN01N23T01	521FN01N23
12	X05.01.A 06+	+24 VDC	521FN01N23
38	X05.01.A 06-	.	.
13	X05.01.A 07	.	.
14	X05.01.A 07+	.	.
39	X05.01.A 07-	.	.
15	X05.01.A 08	.	.
16	X05.01.A 08+	.	.
40	X05.01.A 08-	.	.
17	X05.01.A 09	521CR01N11T01	521CR01N11
18	X05.01.A 09+	+24 VDC	521CR01N11
41	X05.01.A 09-	.	.
19	X05.01.A 10	521CR01N12T01	521CR01N12
20	X05.01.A 10+	+24 VDC	521CR01N12
42	X05.01.A 10-	.	.
21	X05.01.A 11	521CR01N13T01	521CR01N13
22	X05.01.A 11+	+24 VDC	521CR01N13
43	X05.01.A 11-	.	.
23	X05.01.A 12	521CR01N14T01	521CR01N14
24	X05.01.A 12+	+24 VDC	521CR01N14
44	X05.01.A 12-	.	.
25	X05.01.A 13	521CR01N15T01	521CR01N15
26	X05.01.A 13+	+24 VDC	521CR01N15
45	X05.01.A 13-	.	.
27	X05.01.A 14	521CR01N16T01	521CR01N16
28	X05.01.A 14+	+24 VDC	521CR01N16
46	X05.01.A 14-	.	.
29	X05.01.A 15	.	.
30	X05.01.A 15+	.	.
47	X05.01.A 15-	.	.
31	X05.01.A 16	.	.
32	X05.01.A 16+	.	.
48	X05.01.A 16-	.	.

49	17	.	.
50	17-	.	.
51	18	.	.
52	18-	.	.
53	19	.	.
54	19-	.	.
55	20	.	.
56	20-	.	.

520LG01A02
PLC IO-Cabinet ER-51

01	X05.01.A 01	.	.
02	X05.01.A 01+	.	.
33	X05.01.A 01-	.	.
03	X05.01.A 02	.	.
04	X05.01.A 02+	.	.
34	X05.01.A 02-	.	.
05	X05.01.A 03	.	.
06	X05.01.A 03+	.	.
35	X05.01.A 03-	.	.
07	X05.01.A 04	.	.
08	X05.01.A 04+	.	.
36	X05.01.A 04-	.	.
09	X05.01.A 05	.	.
10	X05.01.A 05+	.	.
37	X05.01.A 05-	.	.
11	X05.01.A 06	.	.
12	X05.01.A 06+	.	.
38	X05.01.A 06-	.	.
13	X05.01.A 07	.	.
14	X05.01.A 07+	.	.
39	X05.01.A 07-	.	.
15	X05.01.A 08	.	.
16	X05.01.A 08+	.	.
40	X05.01.A 08-	.	.
17	X05.01.A 09	.	.
18	X05.01.A 09+	.	.
41	X05.01.A 09-	.	.
19	X05.01.A 10	.	.
20	X05.01.A 10+	.	.
42	X05.01.A 10-	.	.
21	X05.01.A 11	.	.
22	X05.01.A 11+	.	.
43	X05.01.A 11-	.	.
23	X05.01.A 12	.	.
24	X05.01.A 12+	.	.
44	X05.01.A 12-	.	.
25	X05.01.A 13	.	.
26	X05.01.A 13+	.	.
45	X05.01.A 13-	.	.
27	X05.01.A 14	.	.
28	X05.01.A 14+	.	.
46	X05.01.A 14-	.	.
29	X05.01.A 15	.	.
30	X05.01.A 15+	.	.
47	X05.01.A 15-	.	.
31	X05.01.A 16	.	.
32	X05.01.A 16+	.	.
48	X05.01.A 16-	.	.

49	X05.01.A 17	.	.
50	X05.01.A 17-	.	.
51	X05.01.A 18	.	.
52	X05.01.A 18-	.	.
53	X05.01.A 19	.	.
54	X05.01.A 19-	.	.
55	X05.01.A 20	.	.
56	X05.01.A 20-	.	.

521JB01AC01

Location :



521JB01A

Analog
Junction Box

80019895

01.001170

521JB01X
Junction Box

A	Signal:	Component:
03	01	521AF01D01S41
02	01+	220 VAC
01	01-	521AF01X01
06	02	521CS01D01S41
05	02+	220 VAC
04	02-	521CS01X01
09	03	521BF01U01C69
08	03+	220 VAC
07	03-	521BF01U01
12	04	521BF01U01U41
11	04+	220 VAC
10	04-	521BF01U01
15	05	521CP01D01P41
14	05+	220 VAC
13	05-	521CP01D01
18	06	521FN01D01S41
17	06+	220 VAC
16	06-	521FN01D01
21	07	521RF01D01S41
20	07+	220 VAC
19	07-	521RF01X01
24	08	521SC01D01S41
23	08+	220 VAC
22	08-	521SC01X01
27	09	521CR01D01S41
26	09+	220 VAC
25	09-	521CR01X01
30	10	521CR01D02S41
29	10+	220 VAC
28	10-	521CR01X02
33	11	521CR01D03Z41
32	11+	220 VAC
31	11-	521CR01D03
36	12	521CR01D04Z41
35	12+	220 VAC
34	12-	521CR01D04
39	13	521CR01R01L41
38	13+	220 VAC
37	13-	521CR01R01
42	14	521CR01R01T41
41	14+	220 VAC
40	14-	521CR01R01
45	15	220 VAC
44	15+	521CR01X01
43	15-	521CR01D04
48	16	220 VAC
47	16+	521CR01R01
46	16-	521CR01R01
⊕		
49	17	521BF01U01C31
50	17-	0/220 VAC
51	18	521CR02Y01C31
52	18-	0/220 VAC
53	19	521CR02Y02C31
54	19-	0/220 VAC
55	20	220 VAC
56	20-	521CR02Y02
57	21	220 VAC
58	21-	521CR02Y01
59	22	220 VAC
60	22-	521CR02Y02
61	23	220 VAC
62	23-	521CR02Y01
63	24	220 VAC
64	24-	521CR02Y02

521JB01XM01

Block	Term:	Component:
X06.01.A	01	521AF01D01S41
X06.01.A	01L	220 VAC
X06.01.A	01N	521AF01X01
X06.01.A	02	521CS01D01S41
X06.01.A	02L	220 VAC
X06.01.A	02N	521CS01X01
X06.01.A	03	521BF01U01C69
X06.01.A	03L	220 VAC
X06.01.A	03N	521BF01U01
X06.01.A	04	521BF01U01U41
X06.01.A	04L	220 VAC
X06.01.A	04N	521BF01U01
X06.01.A	05	521CP01D01P41
X06.01.A	05L	220 VAC
X06.01.A	05N	521CP01D01
X06.01.A	06	521FN01D01S41
X06.01.A	06L	220 VAC
X06.01.A	06N	521FN01D01
X06.01.A	07	521RF01D01S41
X06.01.A	07L	220 VAC
X06.01.A	07N	521RF01X01
X06.01.A	08	521SC01D01S41
X06.01.A	08L	220 VAC
X06.01.A	08N	521SC01X01
X06.01.A	09	521CR01D01S41
X06.01.A	09L	220 VAC
X06.01.A	09N	521CR01X01
X06.01.A	10	521CR01D02S41
X06.01.A	10L	220 VAC
X06.01.A	10N	521CR01X02
X06.01.A	11	521CR01D03Z41
X06.01.A	11L	220 VAC
X06.01.A	11N	521CR01D03
X06.01.A	12	521CR01D04Z41
X06.01.A	12L	220 VAC
X06.01.A	12N	521CR01D04
X06.01.A	13	521CR01R01L41
X06.01.A	13L	220 VAC
X06.01.A	13N	521CR01R01
X06.01.A	14	521CR01R01T41
X06.01.A	14L	220 VAC
X06.01.A	14N	521CR01R01
X06.01.A	15	220 VAC
X06.01.A	15L	521CR01X01
X06.01.A	15N	521CR01D04
X06.01.A	16	220 VAC
X06.01.A	16L	521CR01R01
X06.01.A	16N	521CR01R01
⊕		
X06.01.A	17	521BF01U01C31
X06.01.A	17N	0/220 VAC
X06.01.A	18	521CR02Y01C31
X06.01.A	18N	0/220 VAC
X06.01.A	19	521CR02Y02C31
X06.01.A	19N	0/220 VAC
X06.01.A	20	220 VAC
X06.01.A	20N	521CR02Y02
X06.01.A	21	220 VAC
X06.01.A	21N	521CR02Y01
X06.01.A	22	220 VAC
X06.01.A	22N	521CR02Y02
X06.01.A	23	220 VAC
X06.01.A	23N	521CR02Y01
X06.01.A	24	220 VAC
X06.01.A	24N	521CR02Y02

520LG01A03
PLC IC-Cabinet ER-51

Location :

521JB02A
Junction Box

A	Signal:	Component:
01	521CR01N17T01	521CR01N17
02	+24 VDC	521CR01N17
33		
01-		
03	521CR01N18T01	521CR01N18
04	+24 VDC	521CR01N18
34		
02-		
05	521CR01N21T01	521CR01N21
06	+24 VDC	521CR01N21
35		
03-		
07	521CR01N22T01	521CR01N22
08	+24 VDC	521CR01N22
36		
04+		
09	521CR01N23T01	521CR01N23
10	+24 VDC	521CR01N23
37		
05+		
11	521CR01N24T01	521CR01N24
12	+24 VDC	521CR01N24
38		
06+		
13	521CR01N25T01	521CR01N25
14	+24 VDC	521CR01N25
39		
07+		
15	521CR01N26T01	521CR01N26
16	+24 VDC	521CR01N26
40		
08+		
17	521CR01N27T01	521CR01N27
18	+24 VDC	521CR01N27
41		
09+		
19	521CR01N28T01	521CR01N28
20	+24 VDC	521CR01N28
42		
10+		
21	521CR01N29T01	521CR01N29
22	+24 VDC	521CR01N29
43		
11+		
23	521CR01N30T01	521CR01N30
24	+24 VDC	521CR01N30
44		
12+		
25	521BC02N21T01	521BC02N21
26	+24 VDC	521BC02N21
45		
13+		
27	521BC02N22T01	521BC02N22
28	+24 VDC	521BC02N22
46		
14+		
29	521BC02N23T01	521BC02N23
30	+24 VDC	521BC02N23
47		
15+		
31		
16		
32		
16+		
48		
16-		
49		
17		
50		
17-		
51		
18		
52		
18-		
53		
19		
54		
19-		
55		
20		
56		
20-		

521JB02AC01

520LG01A02
PLC IO-Cabinet ER-51

Block	Term:
01	X05.02.A 01
02	X05.02.A 01+
33	X05.02.A 01-
03	X05.02.A 02
04	X05.02.A 02+
34	X05.02.A 02-
05	X05.02.A 03
06	X05.02.A 03+
35	X05.02.A 03-
07	X05.02.A 04
08	X05.02.A 04+
36	X05.02.A 04-
09	X05.02.A 05
10	X05.02.A 05+
37	X05.02.A 05-
11	X05.02.A 06
12	X05.02.A 06+
38	X05.02.A 06-
13	X05.02.A 07
14	X05.02.A 07+
39	X05.02.A 07-
15	X05.02.A 08
16	X05.02.A 08+
40	X05.02.A 08-
17	X05.02.A 09
18	X05.02.A 09+
41	X05.02.A 09-
19	X05.02.A 10
20	X05.02.A 10+
42	X05.02.A 10-
21	X05.02.A 11
22	X05.02.A 11+
43	X05.02.A 11-
23	X05.02.A 12
24	X05.02.A 12+
44	X05.02.A 12-
25	X05.02.A 13
26	X05.02.A 13+
45	X05.02.A 13-
27	X05.02.A 14
28	X05.02.A 14+
46	X05.02.A 14-
29	X05.02.A 15
30	X05.02.A 15+
47	X05.02.A 15-
31	X05.02.A 16
32	X05.02.A 16+
48	X05.02.A 16-
49	X05.02.A 17
50	X05.02.A 17-
51	X05.02.A 18
52	X05.02.A 18-
53	X05.02.A 19
54	X05.02.A 19-
55	X05.02.A 20
56	X05.02.A 20-

Location :

521JB02X
Junction Box

A	Signal:	Component:
03	521CR01R01U42	521CR01R01
02	220 VAC	521CR01R01
01		
01+		
01-		
06	521CR01R01U43	521CR01R01
02		
05		
02+		
04		
02-		
09	521CR01R01U44	521CR01R01
03		
03+		
07		
03-		
12	521CR01R01Z41	521CR01R01
04		
11		
04+		
10		
04-		
15	521CR01R01Z42	521CR01R01
05		
05+		
14		
06	521CR01R02L41	521CR01R02
18		
06	220 VAC	521CR01R02
17		
06+		
16		
06-		
21	521CR01R02T41	521CR01R02
07		
07+		
19		
07-		
24		
08	521CR01R02U42	521CR01R02
23		
08+	220 VAC	521CR01R02
22		
08-		
27	521CR01R02U43	521CR01R02
09		
09+		
26		
25		
09-		
30	521CR01R02U44	521CR01R02
29		
10+		
28		
10-		
33	521CR01R02Z41	521CR01R02
11		
32		
11+		
31		
11-		
36	521CR01R02Z42	521CR01R02
12		
12+		
35		
12-		
39		
13	521CR02S01Z41	521CR02S01
38		
13+	220 VAC	521CR02S01
37		
13-		
42		
14	521CR02S02Z41	521CR02S02
41		
14+	220 VAC	521CR02S02
40		
14-		
45		
15		
15+		
44		
15-		
43		
48		
16		
47		
16+		
46		
16-		

⊕

49		
17		
50		
17-		
51		
18		
52		
18-		
53		
19		
54		
19-		
55		
20		
56		
20-		
57		
21		
58		
21-		
59		
22		
60		
22-		
61		
23		
62		
23-		
63		
24		
64		
24-		

521JB02XM01

520LG01A03
PLC IC-Cabinet ER-51

Block	Term:	03
X06.02.A	01	
X06.02.A	01L	
X06.02.A	01N	
X06.02.A	02	
X06.02.A	02L	
X06.02.A	02N	
X06.02.A	03	
X06.02.A	03L	
X06.02.A	03N	
X06.02.A	04	
X06.02.A	04L	
X06.02.A	04N	
X06.02.A	05	
X06.02.A	05L	
X06.02.A	05N	
X06.02.A	06	
X06.02.A	06L	
X06.02.A	06N	
X06.02.A	07	
X06.02.A	07L	
X06.02.A	07N	
X06.02.A	08	
X06.02.A	08L	
X06.02.A	08N	
X06.02.A	09	
X06.02.A	09L	
X06.02.A	09N	
X06.02.A	10	
X06.02.A	10L	
X06.02.A	10N	
X06.02.A	11	
X06.02.A	11L	
X06.02.A	11N	
X06.02.A	12	
X06.02.A	12L	
X06.02.A	12N	
X06.02.A	13	
X06.02.A	13L	
X06.02.A	13N	
X06.02.A	14	
X06.02.A	14L	
X06.02.A	14N	
X06.02.A	15	
X06.02.A	15L	
X06.02.A	15N	
X06.02.A	16	
X06.02.A	16L	
X06.02.A	16N	

⊕

49		
17		
50		
17N		
51		
18		
52		
18N		
53		
19		
54		
19N		
55		
20		
56		
20N		
57		
21		
58		
21N		
59		
22		
60		
22N		
61		
23		
62		
23N		
63		
24		
64		
24N		

Location :



521JB02X

Digital
Junction Box

80019895

01.001200

521JB03A
Junction Box

A	Signal:	Component:
01	521BC02N24T01	521BC02N24
02	+24 VDC	521BC02N24
33		
01-		
03	521BC02N25T01	521BC02N25
04	+24 VDC	521BC02N25
34		
02-		
05	521BC02N26T01	521BC02N26
06	+24 VDC	521BC02N26
35		
03-		
07	521BC04N21T01	521BC04N21
08	+24 VDC	521BC04N21
36		
04+		
09	521BC04N22T01	521BC04N22
10	+24 VDC	521BC04N22
37		
05+		
11	521BC04N23T01	521BC04N23
12	+24 VDC	521BC04N23
38		
06+		
13	521BC04N24T01	521BC04N24
14	+24 VDC	521BC04N24
39		
07+		
15	521BC04N25T01	521BC04N25
16	+24 VDC	521BC04N25
40		
08+		
17	521BC04N26T01	521BC04N26
18	+24 VDC	521BC04N26
41		
09+		
19		
10		
20		
10+		
42		
10-		
21		
11		
22		
11+		
43		
11-		
23		
12		
24		
12+		
44		
12-		
25		
13		
26		
13+		
45		
13-		
27		
14		
28		
14+		
46		
14-		
29		
15		
30		
15+		
47		
15-		
31		
16		
32		
16+		
48		
16-		
49		
17		
50		
17-		
51		
18		
52		
18+		
53		
19		
54		
19-		
55		
20		
56		
20-		

521JB03AC01

520LG01A02
PLC IO-Cabinet ER-51

Block	Term:
X05.03.A	01
X05.03.A	01+
33	
X05.03.A	01-
03	
X05.03.A	02
04	
X05.03.A	02+
34	
X05.03.A	02-
05	
X05.03.A	03
06	
X05.03.A	03+
35	
X05.03.A	03-
07	
X05.03.A	04
08	
X05.03.A	04+
36	
X05.03.A	04-
09	
X05.03.A	05
10	
X05.03.A	05+
37	
X05.03.A	05-
11	
X05.03.A	06
12	
X05.03.A	06+
38	
X05.03.A	06-
13	
X05.03.A	07
14	
X05.03.A	07+
39	
X05.03.A	07-
15	
X05.03.A	08
16	
X05.03.A	08+
40	
X05.03.A	08-
17	
X05.03.A	09
18	
X05.03.A	09+
41	
X05.03.A	09-
19	
X05.03.A	10
20	
X05.03.A	10+
42	
X05.03.A	10-
21	
X05.03.A	11
22	
X05.03.A	11+
43	
X05.03.A	11-
23	
X05.03.A	12
24	
X05.03.A	12+
44	
X05.03.A	12-
25	
X05.03.A	13
26	
X05.03.A	13+
45	
X05.03.A	13-
27	
X05.03.A	14
28	
X05.03.A	14+
46	
X05.03.A	14-
29	
X05.03.A	15
30	
X05.03.A	15+
47	
X05.03.A	15-
31	
X05.03.A	16
32	
X05.03.A	16+
48	
X05.03.A	16-
49	
X05.03.A	17
50	
X05.03.A	17-
51	
X05.03.A	18
52	
X05.03.A	18+
53	
X05.03.A	19
54	
X05.03.A	19-
55	
X05.03.A	20
56	
X05.03.A	20-

Location :

521JB03X
Junction Box

A	Signal:	Component:
03 01	521BC01D003Z41	521BC01D03
02 01+	220 VAC	521BC01D03
01 01-		
06 02	521BC01D003Z42	521BC01D03
05 02+		
04 02-		
09 03	521BC01D007S41	521BC01X01
08 03+	220 VAC	521BC01X01
07 03-		
12 04	521BC01D008T41	521BC01D08
11 04+	220 VAC	521BC01D08
10 04-		
15 05		
14 05+		
13 05-		
18 06		
17 06+		
16 06-		
21 07		
20 07+		
19 07-		
24 08		
23 08+		
22 08-		
27 09		
26 09+		
25 09-		
30 10		
29 10+		
28 10-		
33 11		
32 11+		
31 11-		
36 12		
35 12+		
34 12-		
39 13		
38 13+		
37 13-		
42 14		
41 14+		
40 14-		
45 15		
44 15+		
43 15-		
48 16		
47 16+		
46 16-		

⊕

49		
50		
17		
51		
18		
52		
18-		
53		
19		
54		
19-		
55		
20		
56		
20-		
57		
21		
58		
21-		
59		
22		
60		
22-		
61		
23		
62		
23-		
63		
24		
64		
24-		

521JB03XM01

520LG01A03
PLC IO-Cabinet ER-51

Block	Term:	03
X06.03.A	01	03
X06.03.A	01L	02
X06.03.A	01N	01
X06.03.A	02	06
X06.03.A	02L	05
X06.03.A	02N	04
X06.03.A	03	09
X06.03.A	03L	08
X06.03.A	03N	12
X06.03.A	04	11
X06.03.A	04L	10
X06.03.A	04N	15
X06.03.A	05	14
X06.03.A	05L	13
X06.03.A	05N	18
X06.03.A	06	17
X06.03.A	06L	16
X06.03.A	06N	21
X06.03.A	07	20
X06.03.A	07L	19
X06.03.A	07N	24
X06.03.A	08	23
X06.03.A	08L	22
X06.03.A	08N	27
X06.03.A	09	26
X06.03.A	09L	25
X06.03.A	09N	30
X06.03.A	10	29
X06.03.A	10L	28
X06.03.A	10N	33
X06.03.A	11	32
X06.03.A	11L	31
X06.03.A	11N	36
X06.03.A	12	35
X06.03.A	12L	34
X06.03.A	12N	39
X06.03.A	13	38
X06.03.A	13L	37
X06.03.A	13N	42
X06.03.A	14	41
X06.03.A	14L	40
X06.03.A	14N	45
X06.03.A	15	44
X06.03.A	15L	43
X06.03.A	15N	48
X06.03.A	16	47
X06.03.A	16L	46
X06.03.A	16N	

⊕

49		
17		
50		
17N		
51		
18		
52		
18N		
53		
19		
54		
19N		
55		
20		
56		
20N		
57		
21		
58		
21N		
59		
22		
60		
22N		
61		
23		
62		
23N		
63		
24		
64		
24N		

Location :

521JB04X
Junction Box

A	Signal:	Component:
03	521BC02D03Z41	521BC02D03
02	220 VAC	521BC02D03
01		
01+		
01-		
06	521BC02D03Z42	521BC02D03
05		
02+		
02-		
09	521BC02D07S41	521BC02D07
08	220 VAC	521BC02D07
03+	0/220 VAC	521BC02D07
07		
03-	521BC02D08T41	521BC02D08
12		
04	220 VAC	521BC02D08
11		
04+		
10		
04-		
15	521BC02D09T41	521BC02D09
14	220 VAC	521BC02D09
05+		
13		
05-		
18	521BC02D10Z41	521BC02X01
06	220 VAC	521BC02X01
17		
06+		
16		
06-		
21	521BC02D11Z41	521BC02X02
20	220 VAC	521BC02X02
07+		
19		
07-		
24		
08	521BC03D02Z41	521BC03D02
23	220 VAC	521BC03D02
08+		
22		
08-		
27	521BC03D02Z42	521BC03D02
26		
09+		
25		
09-		
30	521BC03D06T41	521BC03D06
29	220 VAC	521BC03D06
10+		
28		
10-		
33	521BC03D07Z41	521BC03X01
32	220 VAC	521BC03X01
11+		
31		
11-		
36		
12	521BC03D08Z41	521BC03X02
35	220 VAC	521BC03X02
12+		
34		
12-		
39	521BC03D09S41	521BC03D09
38	220 VAC	521BC03D09
13+		
37	0/220 VAC	521BC03D09
13-		
42		
14		
14+		
41		
14-		
40		
14+		
45		
15		
15+		
44		
15-		
43		
16		
48		
16+		
47		
16-		
46		

⊕

49		
17		
50		
17-		
51		
18		
18-		
52		
18+		
53		
19		
19-		
54		
19+		
55		
20		
20-		
56		
20+		
57		
21		
21-		
58		
21+		
59		
22		
22-		
60		
22+		
61		
23		
62		
23-		
63		
23+		
64		
24		
24-		

520LG01A03
PLC IC-Cabinet ER-51

Block	Term:	03
X06.04.A	01	
X06.04.A	01L	
X06.04.A	01N	
X06.04.A	02	
X06.04.A	02L	
X06.04.A	02N	
X06.04.A	03	
X06.04.A	03L	
X06.04.A	03N	
X06.04.A	04	
X06.04.A	04L	
X06.04.A	04N	
X06.04.A	05	
X06.04.A	05L	
X06.04.A	05N	
X06.04.A	06	
X06.04.A	06L	
X06.04.A	06N	
X06.04.A	07	
X06.04.A	07L	
X06.04.A	07N	
X06.04.A	08	
X06.04.A	08L	
X06.04.A	08N	
X06.04.A	09	
X06.04.A	09L	
X06.04.A	09N	
X06.04.A	10	
X06.04.A	10L	
X06.04.A	10N	
X06.04.A	11	
X06.04.A	11L	
X06.04.A	11N	
X06.04.A	12	
X06.04.A	12L	
X06.04.A	12N	
X06.04.A	13	
X06.04.A	13L	
X06.04.A	13N	
X06.04.A	14	
X06.04.A	14L	
X06.04.A	14N	
X06.04.A	15	
X06.04.A	15L	
X06.04.A	15N	
X06.04.A	16	
X06.04.A	16L	
X06.04.A	16N	

⊕

49		
17		
50		
17N		
51		
18		
18N		
52		
19		
19N		
53		
20		
20N		
54		
21		
21N		
55		
22		
22N		
56		
23		
23N		
57		
24		
24N		

521JB04XM01

Location :



521JB04X

Digital
Junction Box

80019895

01.001230

521JB05X
Junction Box

A	Signal:	Component:
03	521BC04D09Z41	521BC04D09
02	220 VAC	521BC04D09
01+		
01-		
06	521BC04D09Z42	521BC04D09
05		
02+		
04		
02-		
09		
03	521BC04D15S41	521BC04D15
03+	220 VAC	521BC04D15
07	0/220 VAC	521BC04D15
03-		
12	521BC04D16T41	521BC04D16
04		
04	220 VAC	521BC04D16
11		
04+		
10		
04-		
15	521BC04D17T41	521BC04D17
05	220 VAC	521BC04D17
14		
05+		
13		
05-		
18	521BC04D18Z41	521BC04X01
06	220 VAC	521BC04X01
17		
06+		
16		
06-		
21	521BC04D19Z41	521BC04X02
07	220 VAC	521BC04X02
20		
07+		
19		
07-		
24		
08		
23		
08+		
22		
08-		
27		
09		
26		
09+		
25		
09-		
30		
10		
29		
10+		
28		
10-		
33		
11		
32		
11+		
31		
11-		
36		
12		
35		
12+		
34		
12-		
39		
13		
38		
13+		
37		
13-		
42		
14	521BC06D01Z41	521BC06D01
41	220 VAC	521BC06D01
40		
14+		
45		
15	521BC06D01Z42	521BC06D01
44		
15+		
43		
15-		
48		
16		
47		
16+		
46		
16-		

520LG01A03
PLC IC-Cabinet ER-51

Block	Term:	Term:
X06.05.A	01	03
X06.05.A	01L	02
X06.05.A	01N	01
X06.05.A	02	06
X06.05.A	02L	05
X06.05.A	02N	04
X06.05.A	03	09
X06.05.A	03L	08
X06.05.A	03N	07
X06.05.A	04	12
X06.05.A	04L	11
X06.05.A	04N	10
X06.05.A	05	15
X06.05.A	05L	14
X06.05.A	05N	13
X06.05.A	06	18
X06.05.A	06L	17
X06.05.A	06N	16
X06.05.A	07	21
X06.05.A	07L	20
X06.05.A	07N	19
X06.05.A	08	24
X06.05.A	08L	23
X06.05.A	08N	22
X06.05.A	09	27
X06.05.A	09L	26
X06.05.A	09N	25
X06.05.A	10	30
X06.05.A	10L	29
X06.05.A	10N	28
X06.05.A	11	33
X06.05.A	11L	32
X06.05.A	11N	31
X06.05.A	12	36
X06.05.A	12L	35
X06.05.A	12N	34
X06.05.A	13	39
X06.05.A	13L	38
X06.05.A	13N	37
X06.05.A	14	42
X06.05.A	14L	41
X06.05.A	14N	40
X06.05.A	15	45
X06.05.A	15L	44
X06.05.A	15N	43
X06.05.A	16	48
X06.05.A	16L	47
X06.05.A	16N	46

521JB05XM01

Location :

LVDB 582ER51MC01

521MT01S01
Start/Stop/E-stop

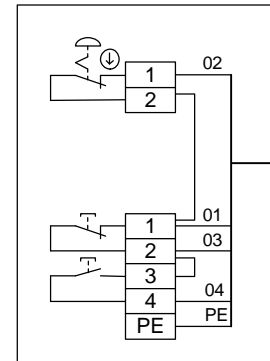

521MT01S01M01

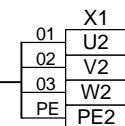
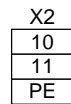
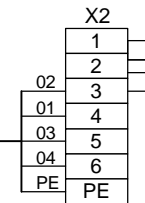

521MT01M01W01

No of cables 1

521MT01M01
Motor
14.5 kW (Derated)
15 kW

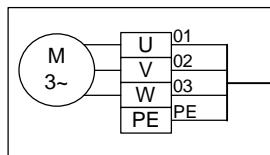

MCC Position:
Unit Type: B01 - NO
Net: 520LG01:DP5
Node: MCC/MDB 2.039
521MT01Q01
Motor Starter



521MT01M01

Magnetic Separator
Motor

80019895

01.001250

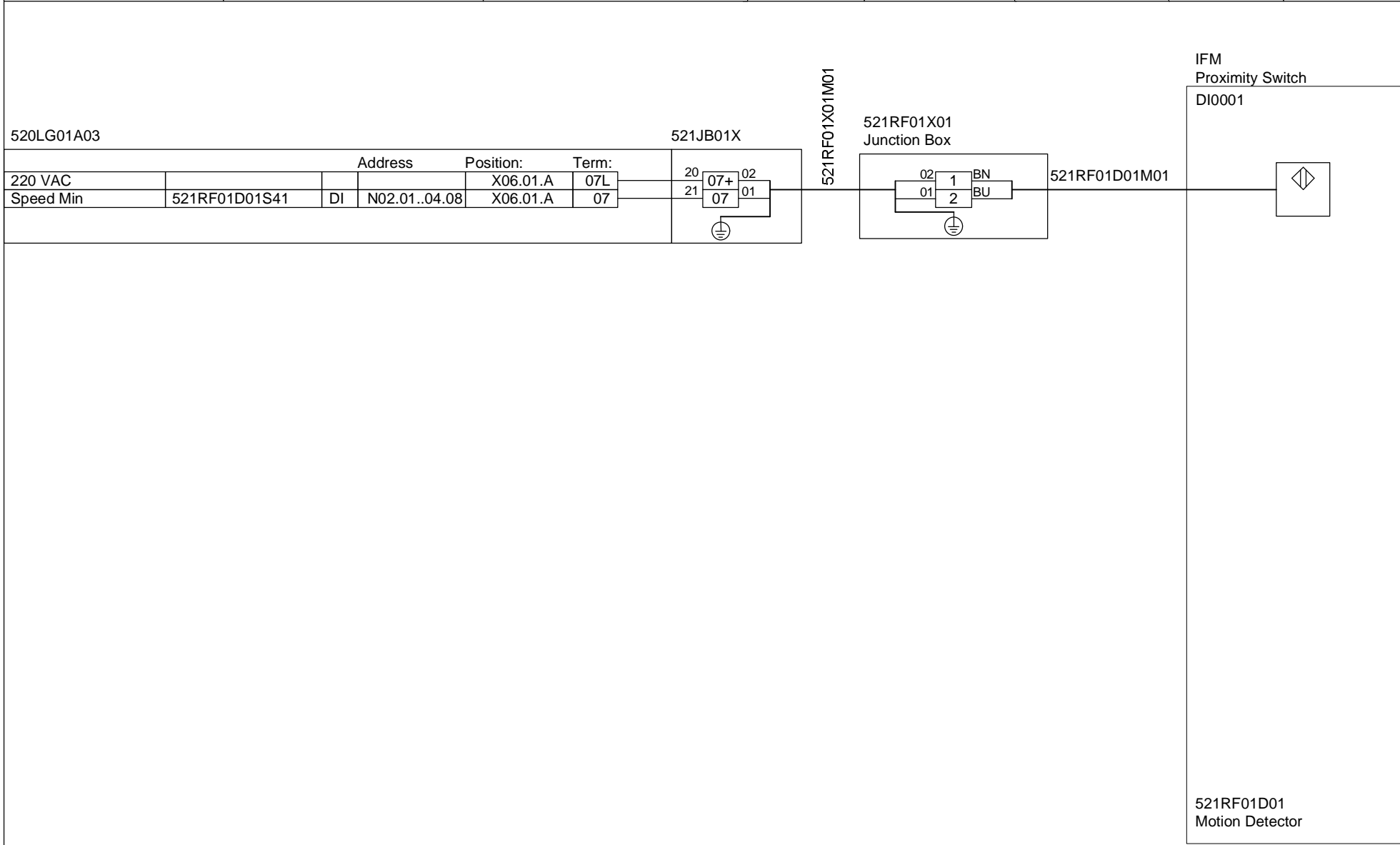

LVDB 582ER51MC01

521RF01S01
Start/Stop/E-stop

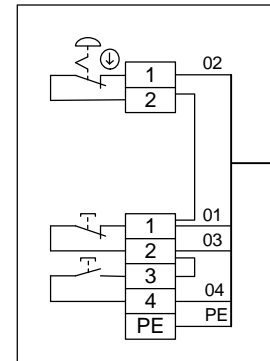

521RF01S01M01

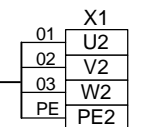
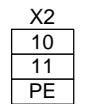
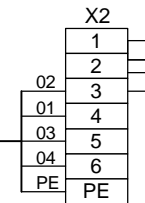

521RF01M01W01

No of cables 1

521RF01M01
Motor
0.75 kW (Derated)
0.75 kW

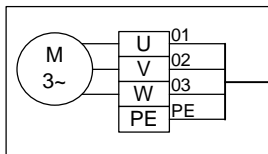

MCC Position:
Unit Type: B01 - NO
Net: 520LG01:DP5
Node: MCC/MDB 2.033
521RF01Q01
Motor Starter



521RF01M01

Rotary Feeder
Motor

80019895

01.001270

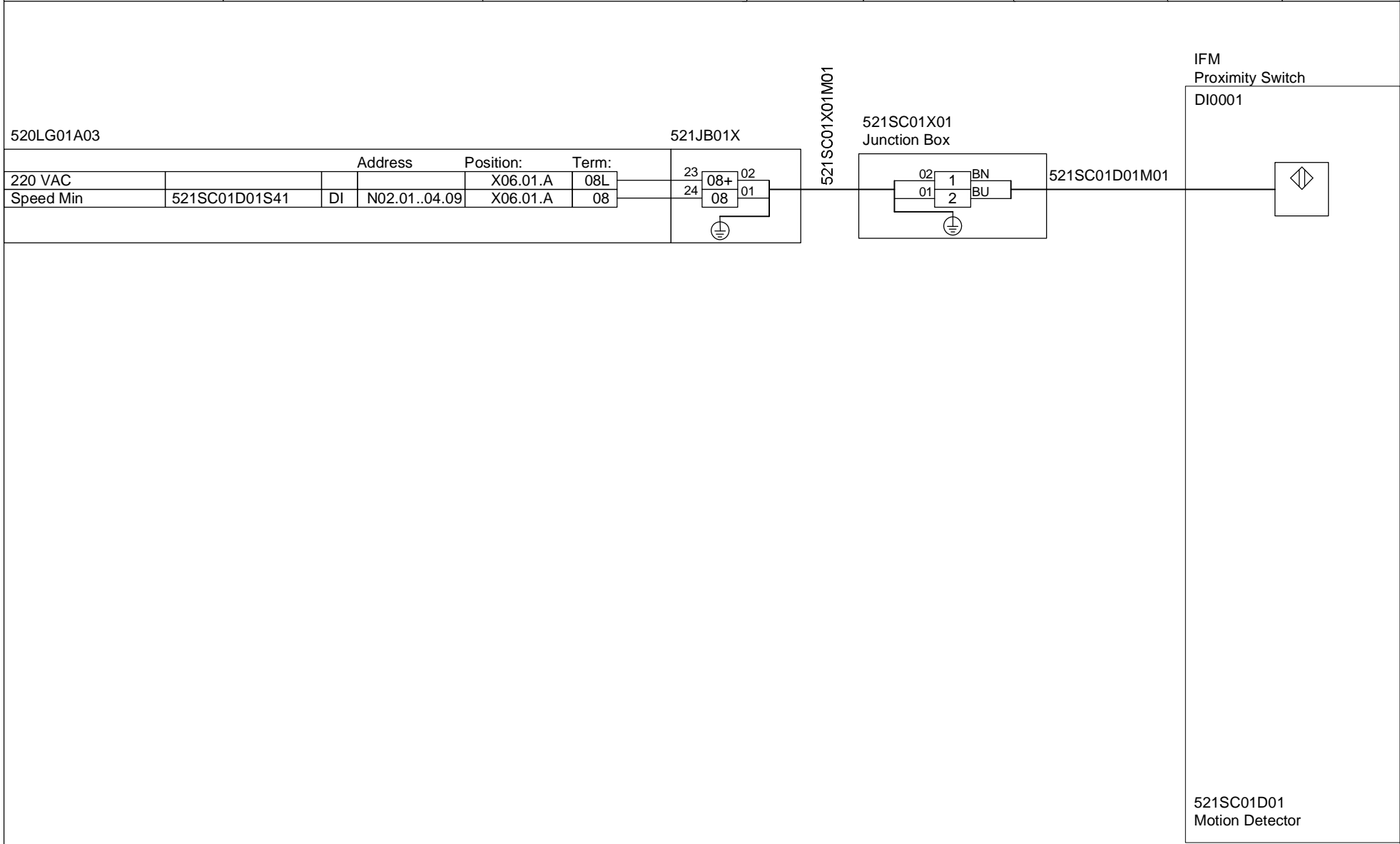

LVDB 582ER51MC01

521SC01S01
Start/Stop/E-stop

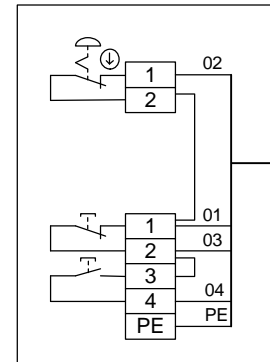

521SC01S01M01

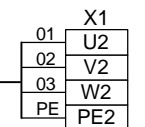
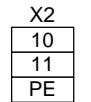
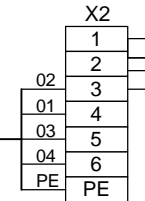

521SC01M01W01

No of cables 1

521SC01M01
Motor
2.2 kW (Derated)
2.2 kW

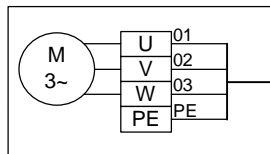

MCC Position:
Unit Type: B01 - NO
Net: 520LG01:DP5
Node: MCC/MDB 2.034
521SC01Q01
Motor Starter



521SC01M01

Screw Conveyor
Motor

80019895

01.001290

Tonasa	DL Generic (Single-DI)	DL Generic (Single-DI)	-	5/2/2011 7:30:06 AM	12/22/2011 12:53:05 PM	Customer	A1
--------	------------------------	------------------------	---	---------------------	------------------------	----------	----

520LG01A03

	Address	Position	Term:
220 VAC		X06.07.A	05L ⁰²
Level Switch	521SJ01D01L41	X06.07.A	05 ⁰¹
			⊕

521SJ01D01M01

Customer
Supply

02	1
01	2
PE	PE

This drawing needs detailed information from Client on terminals to be connected.

Terminals considered now are tentative

521SJ01D01
Switch

	521SJ01D01	Sump Pump Level Switch	80019895	01.001300
--	------------	------------------------	----------	-----------

LVDB 582ER51MC01

521SJ01S01
Start/Stop/E-stop

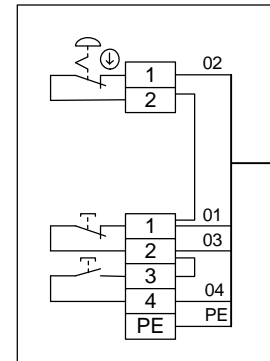

521SJ01S01M01

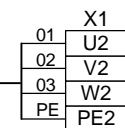
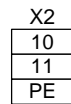
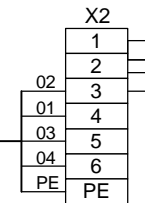

521SJ01M01W01

No of cables 1

521SJ01M01
Motor
7.5 kW (Derated)
7.5 kW

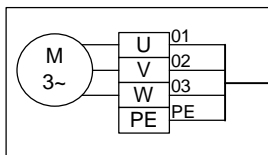

MCC Position:
Unit Type: B01 - NO
Net: 520LG01:DP5
Node: MCC/MDB 2.035
521SJ01Q01
Motor Starter



521SJ01M01

Drain Pump
Motor

80019895

01.001310

Tonasa	Schade 521TR01	Schade Tripper 521TR01	ARDN-IN	11/23/2010 7:34:03 AM	12/26/2011 12:23:51 PM	Customer	A1
--------	----------------	------------------------	---------	-----------------------	------------------------	----------	----

Schade

Tripper

LVDB 582ER51MC01

X1	
1	01
3	02
5	03
PE	PE

MCC Position:
Unit Type: B28
521TR01Q01 Feeder

521TR01Q01W01

No of cables 2

X	
01	L1
02	L2
03	L3
PE	PE

521TR01A01
Control Panel



521TR01A01

Tripper
Control Panel

80019895

01.001320



520LG01A03

	Address	Position	Term:
220 VAC		X06.06.A	08L
Speed Min	523AF01D01S41	X06.06.A	08

523JB01X

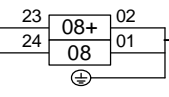

523AF01D01M01

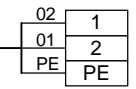

Customer
Supply

This drawing needs detailed information from Client on terminals to be connected.

Terminals considered now are tentative

523AF01D01
Motion Detector

LVDB 582ER52AMC03

523AF01S01
Start/Stop/E-stop

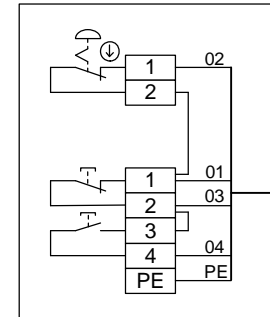

523AF01S01M01

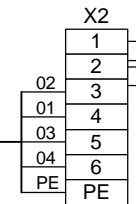

523AF01M01
Motor

Document: 80019895
Page: 01.001350

523AF01M01C01

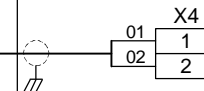

523AF01U01
Frequency Converter

Document: 80019895
Page: 01.001350

523AF01U01W01

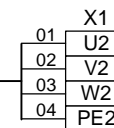

MCC Position:
Unit Type: B15.1-UD-TH
Net: 520LG01:DP4
Node: MCC/MDB 1.011
523AF01Q01
Motor Starter

ABB
Frequency Drive
ACS850-04-044A-
5+E200+J410+K454

582ER52AMC03F01
Feeder

523AF01U01M01

Document: 80019895
Page: 01.002050

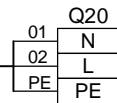

523AF01Q01
Motor Starter

523AF01M01C01

Doc: 80019895
Page: 01.001340

523AF01M01
Motor
22 kW

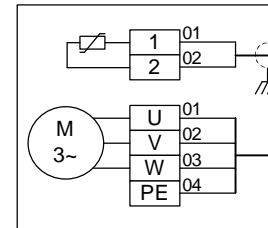

523AF01M01W01

No of cables 1

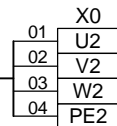

523AF01Q01
Motor Starter

523AF01U01W01

Document: 80019895
Page: 01.001340

No of cables 1

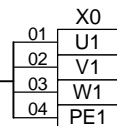

Net: 520LG01:DP3
Node: Field Device.012

523AF01U01
Frequency Converter

ABB
 Frequency Drive
 ACS850-04-044A-
 5+E200+J410+K454

520LG01A13
 Network Interface Box Profibus 523AF01U01Y01
 Document: 80019895
 Page: 01.000190

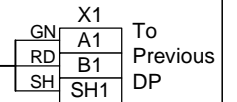

523AF01U01
 Frequency Converter

523BC01S01
Start/Stop/E-stop

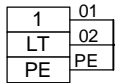

Document: 80019895
Page: 01.001400

Kiepe
Pull Rope Switch

NTS 002

523BC01D01M01

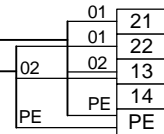

523BC01D02M01

523BC01D01
Pull Rope Switch

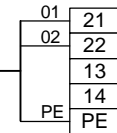

523BC01D02
Pull Rope Switch

520LG01A03

523JB01X

	Address	Position:	Term:
220 VAC		X06.06.A	10L
Sway Max 1	523BC01D03Z41	DI N02.01..07.33	10
Sway Max 2	523BC01D03Z42	DI N02.01..07.34	11

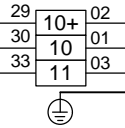

Kiepe
Off Track Limit Switch

SLS 011

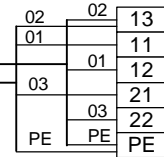

523BC01D03M01

523BC01D04M01

523BC01D05M01

523BC01D06M01

523BC01D03
Sway Detector

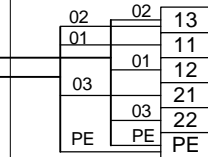

523BC01D04
Sway Detector

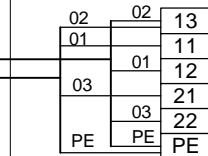

523BC01D05
Sway Detector

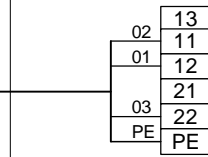

523BC01D06
Sway Detector



523BC01D03

Discharge Belt conveyor
Sway Detector

80019895

01.001380

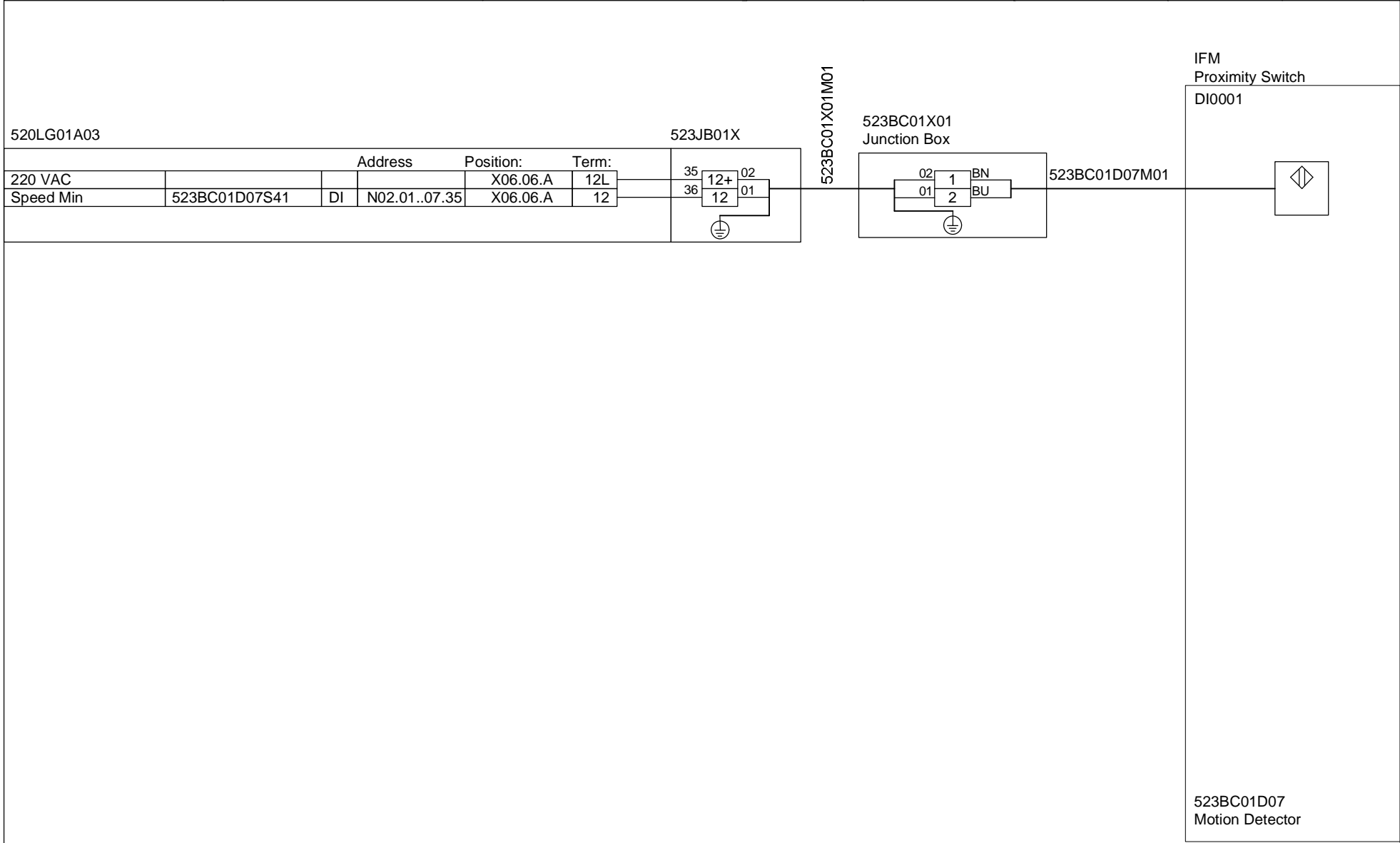

520LG01A03

523JB01X

523BC01X01M01

523BC01X01
Junction Box

IFM
Proximity Switch
DI0001

	Address	Position:	Term:
220 VAC		X06.06.A	12L
Speed Min	523BC01D07S41	X06.06.A	12

523BC01D07M01

523BC01D07
Motion Detector

LVDB 582ER52AMC03

523BC01S01
Start/Stop/E-stop

523BC01D01
Pull Rope Switch
523BC01D01M01
Document: 80019895
Page: 01.001370

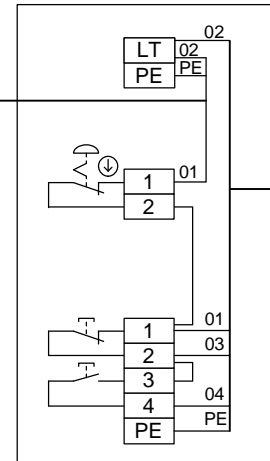

523BC01S01M01

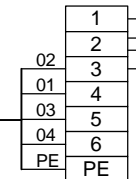

X2



523BC01M01
Motor
11 kW (Derated)
11 kW

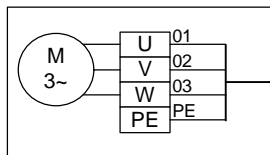

523BC01M01W01

No of cables 1

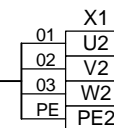

MCC Position:
Unit Type: B01 - NO
Net: 520LG01:DP4
Node: MCC/MDB 1.012
523BC01Q01
Motor Starter



523BC01M01

Discharge Belt conveyor
Motor

80019895

01.001400

523BC02S01
Start/Stop/E-stop

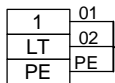

Document: 80019895
Page: 01.001480

Kiepe
Pull Rope Switch
NTS 002

523BC02D01M01

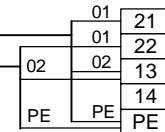

523BC02D02M01

523BC02D01
Pull Rope Switch

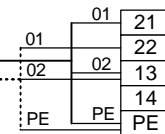

Cable List: Pull Rope switches

- 523BC02D03M01
- 523BC02D04M01
- 523BC02D05M01

523BC02D06M01

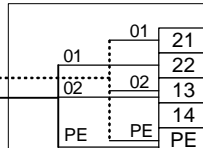

523BC02D06
Pull Rope Switch

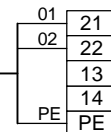

520LG01A03

523JB01X

	Address	Position:	Term:	
220 VAC			01L	02
Sway Max 1	523BC02D07Z41	DI	N02.01..07.22	X06.06.A
Sway Max 2	523BC02D07Z42	DI	N02.01..07.23	X06.06.A

Kiepe
Off Track Limit Switch

SLS 011

523BC02D07M01

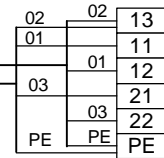

523BC02D08M01

523BC02D07
Sway Detector

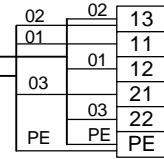

523BC02D09M01

523BC02D08
Sway Detector

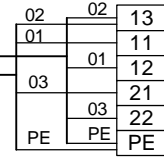

523BC02D10M01

523BC02D09
Sway Detector

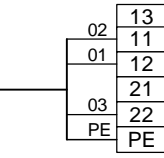

523BC02D10
Sway Detector



523BC02D07

Belt Conveyor
Sway Detector

80019895

01.001420

520LG01A03

523JB01X

	Address	Position:	Term:	
0/220 VAC		X06.06.A	03N	07
220 VAC		X06.06.A	03L	08
Speed Min	523BC02D11S41	DI	N02.01..07.24	X06.06.A
				03

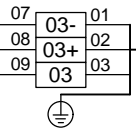

523BC02D11M01

Milltronics
ZSS

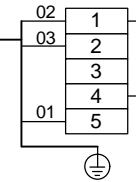

523BC02D11
Motion Detector



523BC02D11

Belt Conveyor
Motion Detector

80019895

01.001430

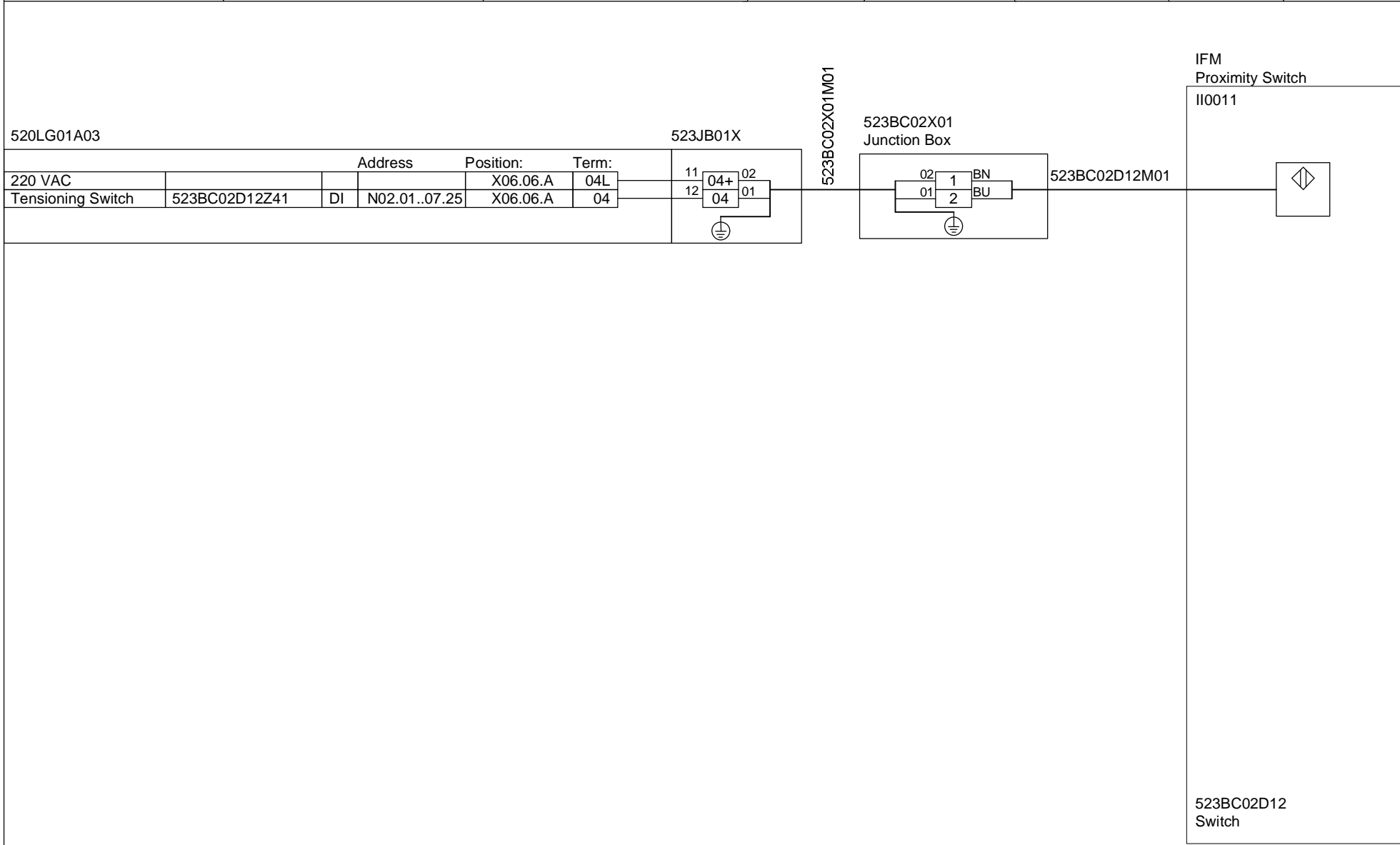

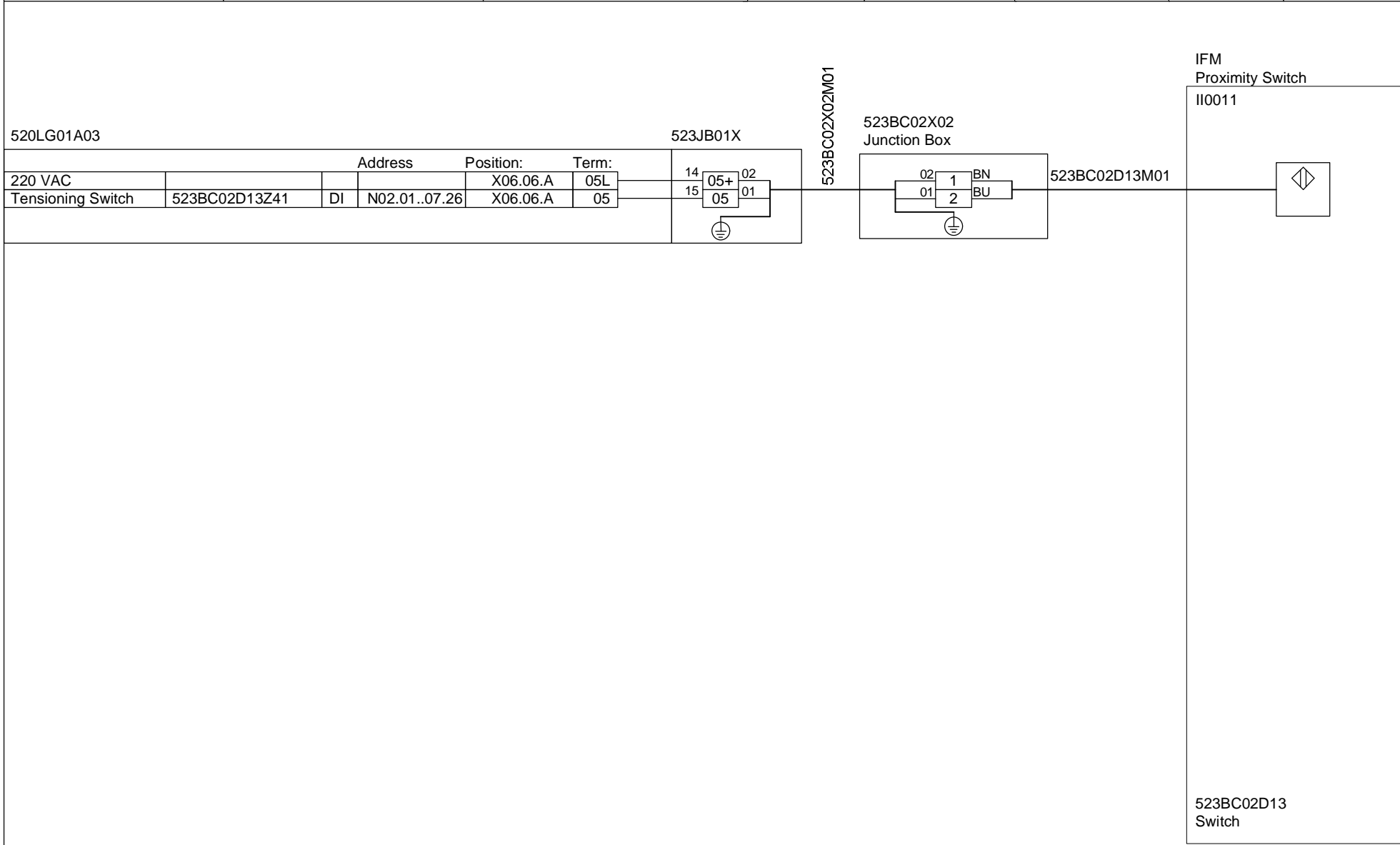

520LG01A03

523JB01X

	Address	Position:	Term:
220 VAC		X06.06.A	06L
Temperature High	523BC02D14T41	DI	N02.01..07.27
		X06.06.A	06

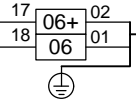

523BC02D14M01

Panasonic
Limit Switch

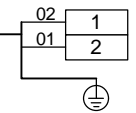

523BC02D14
Temperature

520LG01A03

523JB01X

Schmersal
Position Switch
M3R330-11Y

	Address	Position	Term:
220 VAC		X06.06.A	07L
Open	523BC02D15Z41	DI N02.01..07.28	X06.06.A 07

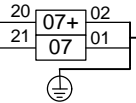

523BC02D15M01

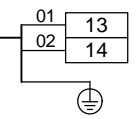

523BC02D15
Limit Switch

LVDB 582ER52AMC03

523BC02S01
Start/Stop/E-stop

523BC02D01
Pull Rope Switch

523BC02D01M01

Document: 80019895
Page: 01.001410

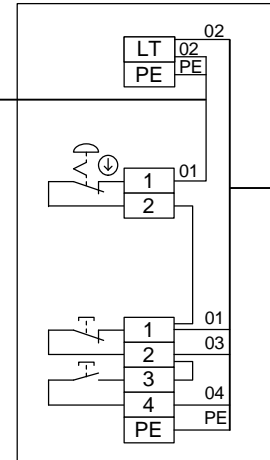

523BC02S01M01

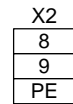
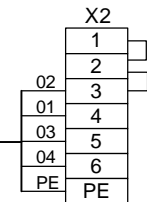

523BC02M01C01

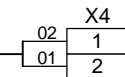

523BC02M01W01

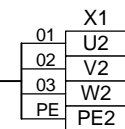

No of cables 1

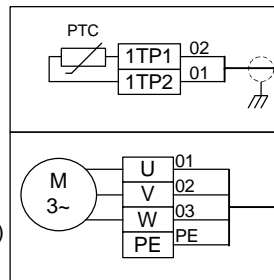

523BC02M01
Motor
36 kW (Derated)
37 kW

MCC Position:
Unit Type: B01 - TH
Net: 520LG01:DP4
Node: MCC/MDB 1.013
523BC02Q01 Motor Starter



523BC02M01

Belt Conveyor
Motor

80019895

01.001480

LVDB 582ER52AMC03

523BC02S02
Start/Stop/E-stop

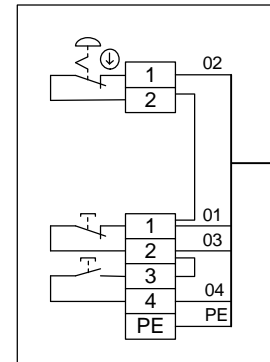

523BC02S02M01

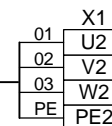
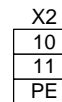
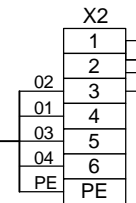

523BC02M02W01

No of cables 1

523BC02M02
Motor
0.38 kW (Derated)
0.38 kW

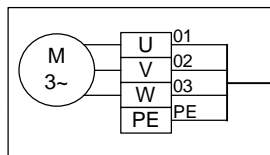

MCC Position:
Unit Type: B01 - NO
Net: 520LG01:DP4
Node: MCC/MDB 1.014
523BC02Q02
Motor Starter



523BC02M02

Belt Conveyor Brake
Motor

80019895

01.001490

Tonasa	A Crane/Hoist	Cranes / Hoist	-	9/14/2010 6:03:20 AM	12/22/2011 12:53:15 PM	Customer	A1
--------	---------------	----------------	---	----------------------	------------------------	----------	----

Customer
Supply

LVDB 582ER52AMC03

X0	
U2	01
V2	02
W2	03

MCC Position:
Type: B32
523CA01Q01 Power Feeder

523CA01Q01W01

No of cables 1

01	U1
02	V1
03	W1

523CA01A01
Cabinet



523CA01A01

Crane
Cabinet

80019895

01.001500

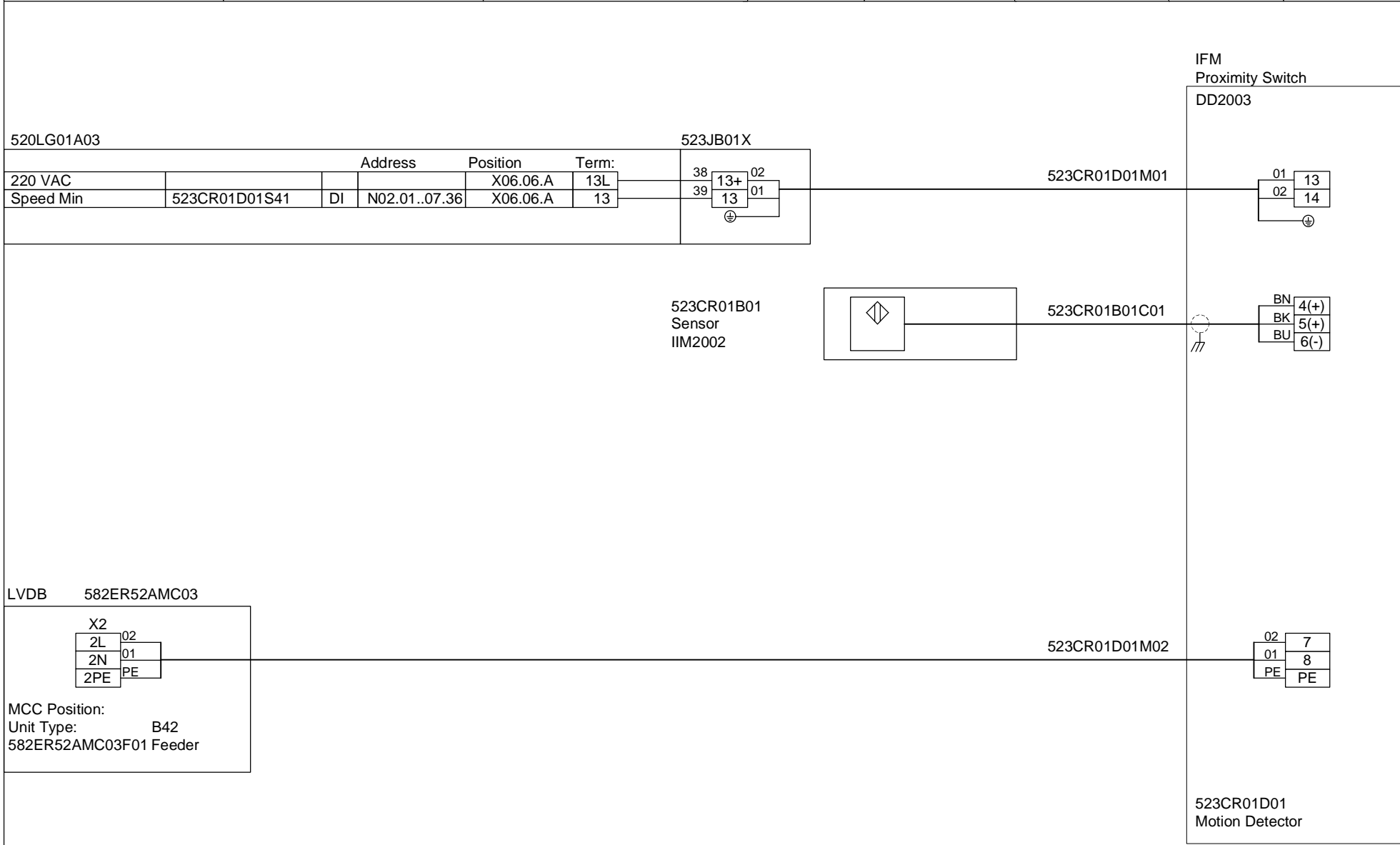

520LG01A03

523JB01X

IFM
Proximity Switch
DD2003

	Address	Position	Term:
220 VAC		X06.06.A	13L
Speed Min	523CR01D01S41	DI N02.01..07.36	X06.06.A 13

523CR01B01
Sensor
IIM2002

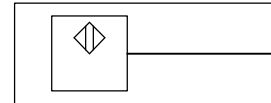

LVDB 582ER52AMC03

X2	02
2L	01
2N	PE
2PE	

MCC Position:
Unit Type: B42
582ER52AMC03F01 Feeder

523CR01D01
Motion Detector



523CR01D01

Crusher
Motion Detector

80019895

01.001510

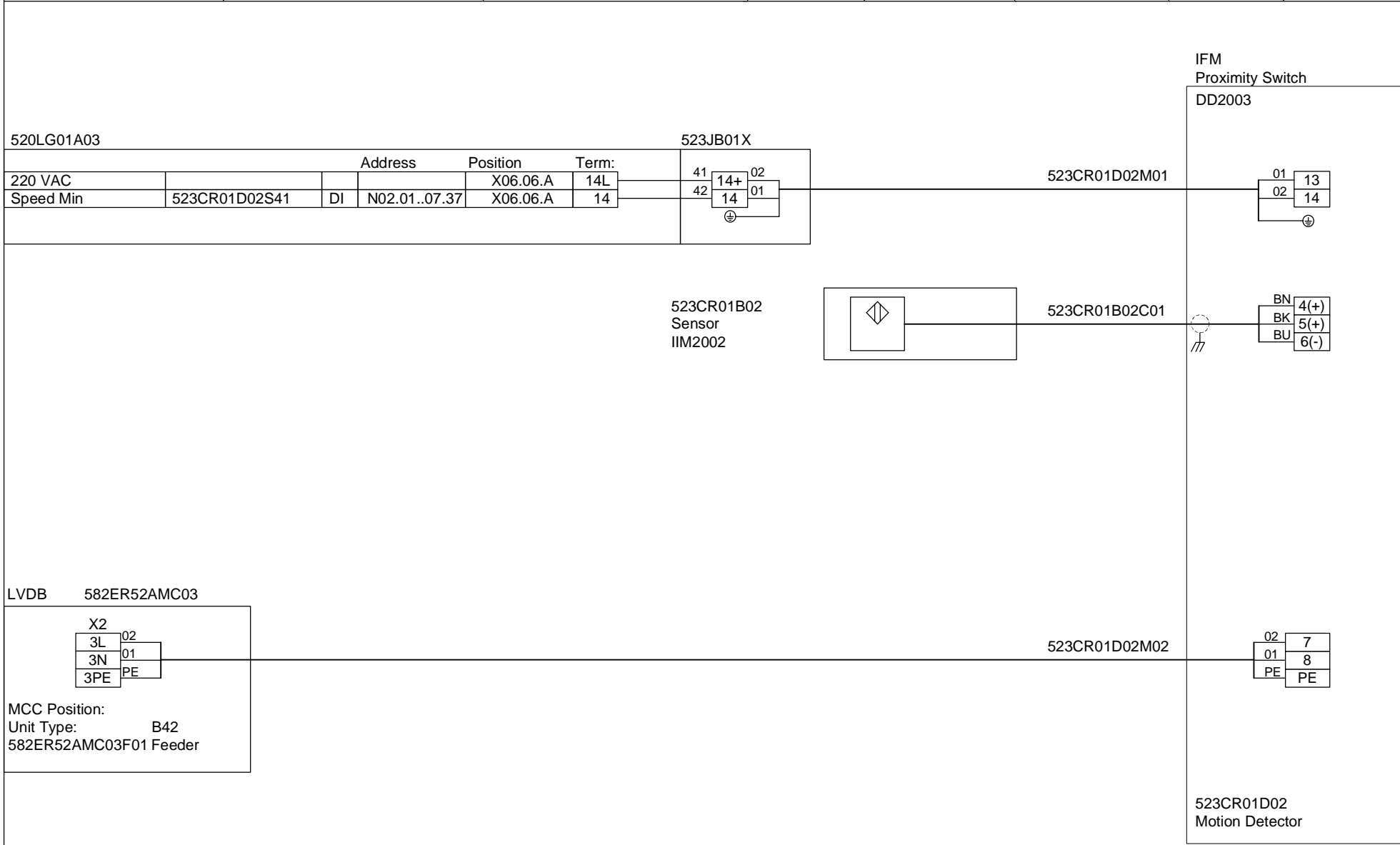

520LG01A03

523JB01X

KWD
Temperature Transmitter
KWD 39000

220 VAC	Temperature Coupling	523CR01D03T41	DI	Address	Position	Term:
				N02.01..07.38	X06.06.A	15L
					X06.06.A	15

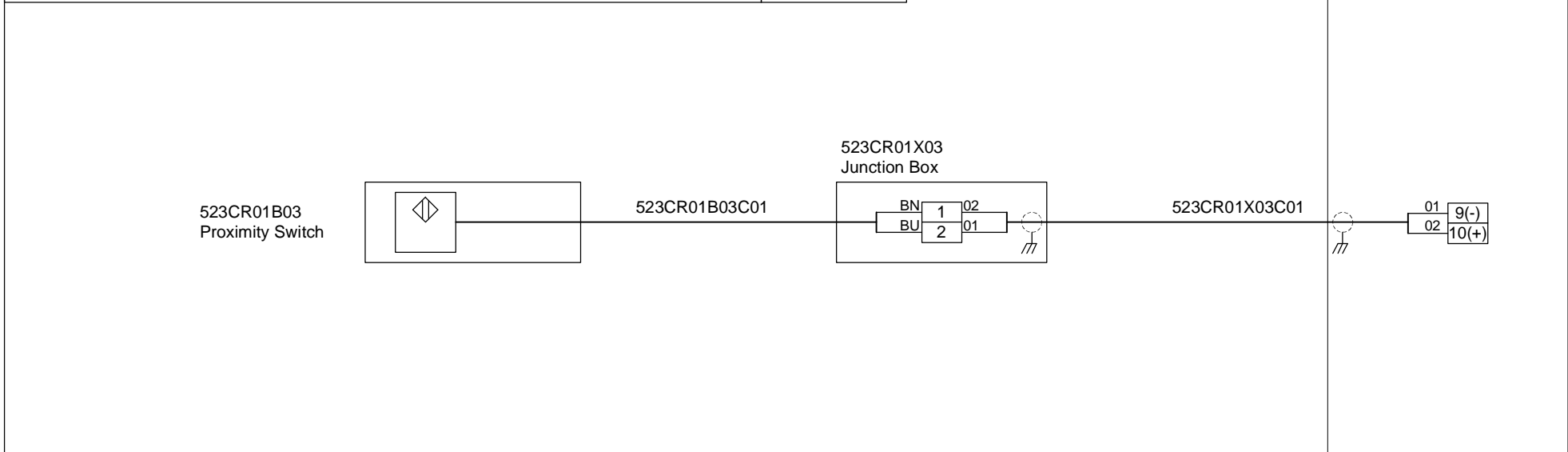

LVDB 582ER52AMC03

X2	01
4N	02
4L	PE
4PE	PE

MCC Position:
Unit Type: B42
582ER52AMC03F01 Feeder

523CR01D03M02

01	1
02	2
PE	PE

523CR01D03 Temperature



Address	Position	Term:
220 VAC	X06.06.A	16L
Temperature Coupling	X06.06.A	16

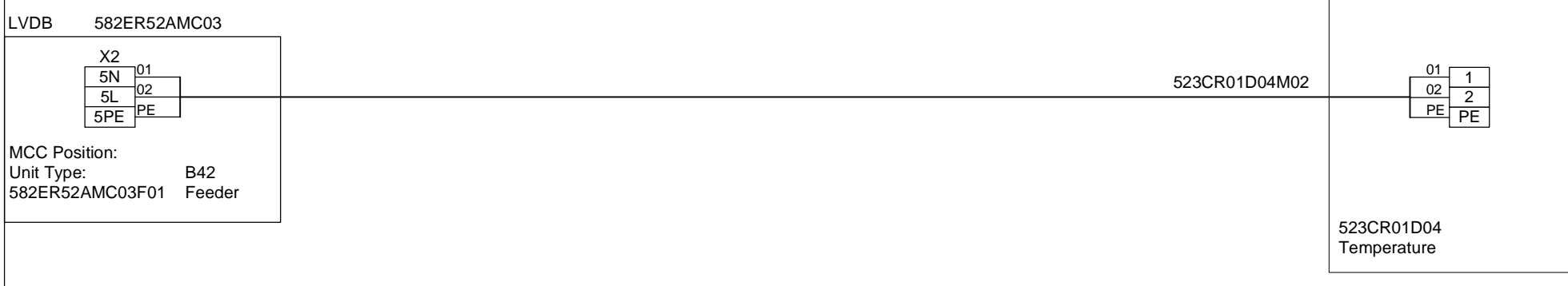
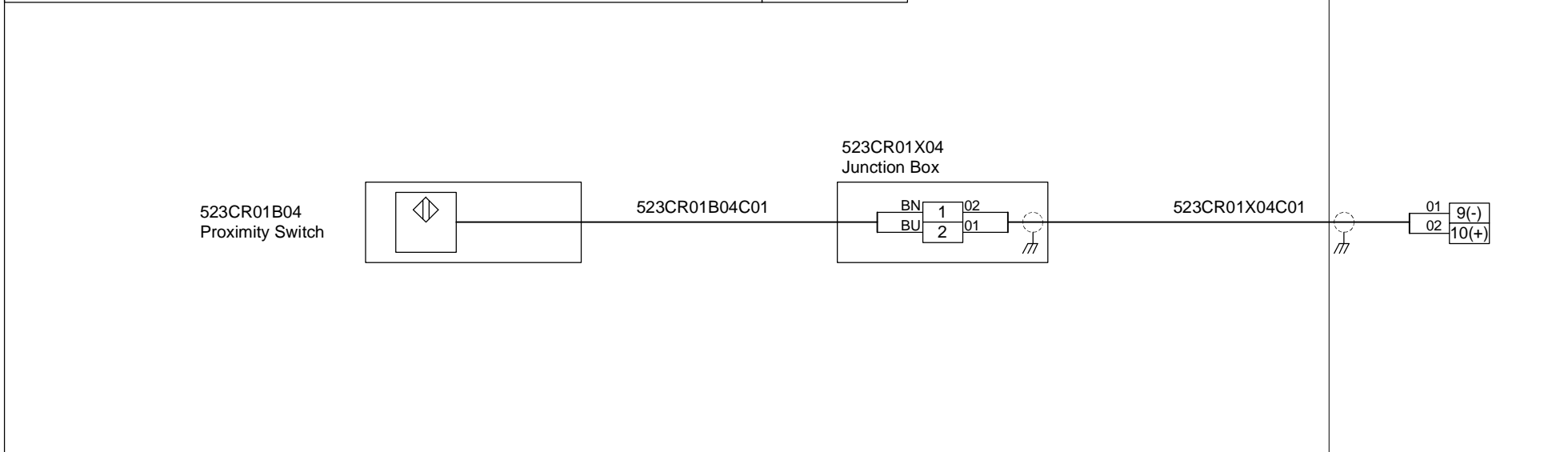

MCC Position:
 Unit Type: B42
 582ER52AMC03F01 Feeder

KWD
 Temperature Transmitter
 KWD 39000

523CR01D04
 Temperature

LVDB 582ER52AMC03

523CR01S03
Start/Stop/E-stop

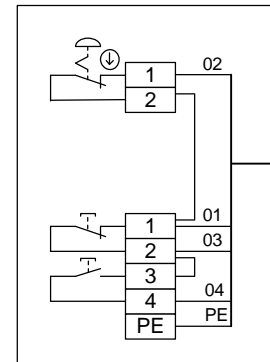

523CR01S03M01

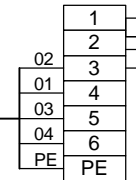

523CR01E01
Heating Element
kW (Derated)
kW

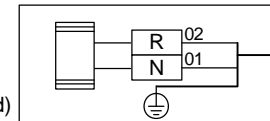

523CR01E01M01

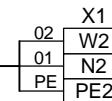

Position:
Unit Conn. Type: B22
Net: 520LG01:DP4
Node: MCC/MDB 1.017
523CR01Q03 Motor Starter



523CR01E01

Crusher
Heating Element -1

80019895

01.001550

LVDB 582ER52AMC03

523CR01S04
Start/Stop/E-stop

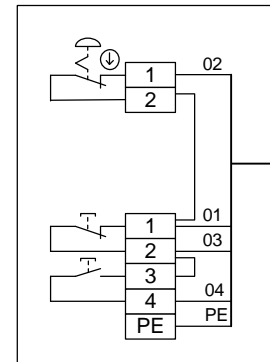

523CR01S04M01

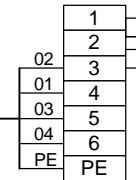

523CR01E02
Heating Element
kW (Derated)
kW

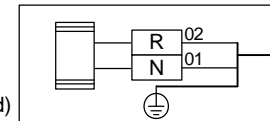

523CR01E02M01

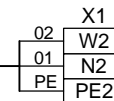

Position:
Unit Conn. Type: B22
Net: 520LG01:DP4
Node: MCC/MDB 1.018
523CR01Q04 Motor Starter



523CR01E02

Crusher
Heating Element -2

80019895

01.001560

LVDB 582ER52AMC03

523CR01S01
Start/Stop/E-stop

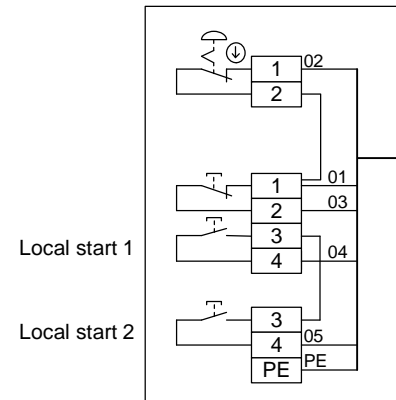

523CR01S01M01

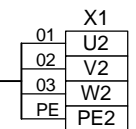
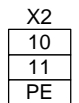
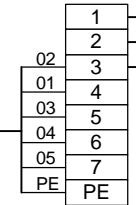

523CR01M01W01

No of cables 1

523CR01M01
Motor
106 kW (Derated)
110 kW

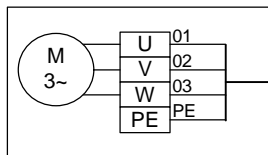

MCC Position:
Unit Type: B11-PM
Net: 520LG01:DP4
Node: MCC/MDB 1.015
523CR01Q01
Motor Starter



523CR01M01

Crusher
Motor

80019895

01.001570

LVDB 582ER52AMC03

523CR01S02
Start/Stop/E-stop

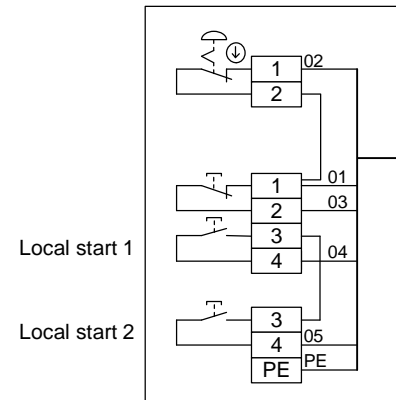

Local start 1

Local start 2

523CR01S02M01

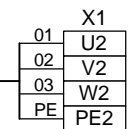
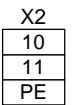
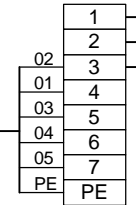

523CR01M02
Motor
106 kW (Derated)
110 kW

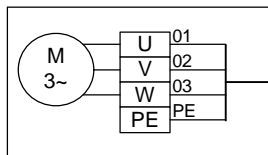

523CR01M02W01

No of cables 1

MCC Position:
Unit Type: B11-PM
Net: 520LG01:DP4
Node: MCC/MDB 1.016
523CR01Q02
Motor Starter



523CR01M02

Crusher
Motor

80019895

01.001580

520LG01A02

523JB01A

	Address	Position:	Term:
+24 VDC		X05.04.A	01+
Temperature	523CR01N11T01	AI N02.02..05.02	X05.04.A 01

Customer Supply

523CR01B11
Sensor

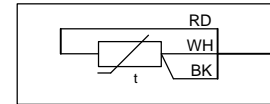

523CR01N11C01

523CR01B11C01

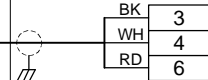
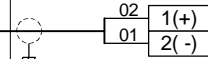

Range 0 - 130 °C

523CR01N11

Temperature



523CR01N11 Crusher Rotor Bearing 1
Temperature

80019895

01.001590

520LG01A02

523JB01A

	Address	Position:	Term:
+24 VDC		X05.04.A	02+
Temperature	523CR01N12T01	AI N02.02..05.04	X05.04.A 02

Customer Supply

523CR01B12
Sensor

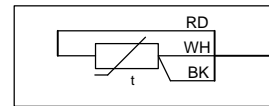

523CR01N12C01

523CR01B12C01

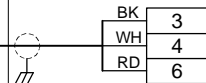
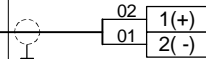

Range 0 - 130 °C

523CR01N12

Temperature



523CR01N12 Crusher Rotor Bearing 2
Temperature

80019895

01.001600

520LG01A02

523JB01A

	Address	Position:	Term:
+24 VDC		X05.04.A	05+
Temperature	523CR01N14T01	AI N02.02..05.12	X05.04.A 05

Customer Supply

523CR01B14 Sensor

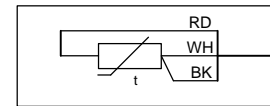

Pt100

523CR01N14C01

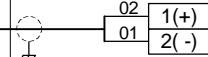

523CR01B14C01

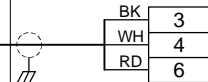

Range 0 - 170 °C

523CR01N14

Temperature

520LG01A02

523JB01A

	Address	Position:	Term:
+24 VDC		X05.04.A	06+
Temperature	523CR01N15T01	AI N02.02..05.14	X05.04.A 06

Customer Supply

523CR01B15 Sensor

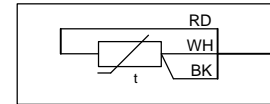

523CR01N15C01

523CR01B15C01

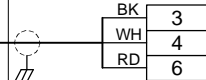
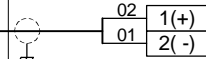

Range 0 - 130 °C

523CR01N15

Temperature



523CR01N15 Crusher Rotor Bearing 1 Temperature

80019895

01.001620

520LG01A02

523JB01A

	Address	Position:	Term:
+24 VDC		X05.04.A	07+
Temperature	523CR01N16T01	AI N02.02..05.16	X05.04.A 07

Customer
Supply

523CR01B16
Sensor

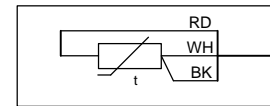

523CR01N16C01

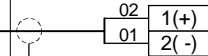

523CR01B16C01

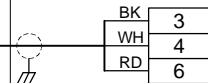

Range 0 - 130 °C

523CR01N16

Temperature



523CR01N16 Crusher Rotor Bearing 2
Temperature

80019895

01.001630

520LG01A02

523JB01A

	Address	Position:	Term:
+24 VDC		X05.04.A	10+
Temperature	523CR01N18T01	AI N02.02..06.04	X05.04.A 10

Customer Supply

523CR01B18 Sensor

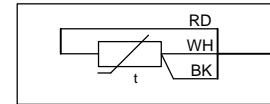

523CR01N18C01

523CR01B18C01

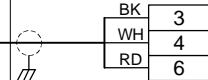
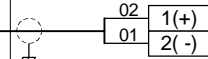

Range 0 - 170 °C

523CR01N18

Temperature



523CR01N18 Crusher Gear Temperature

80019895

01.001640

520LG01A02

523JB01A

	Address	Position	Term:
+24 VDC		X05.04.A	03+
Temperature	523CR01N19T01	AI N02.02..05.06	X05.04.A 03

Customer
Supply

523CR01N19C01

This model needs detailed information from Client on terminals to be connected.

Terminals considered now are tentative

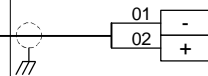

Range 0 - 150 °C

523CR01N19
Temperature



523CR01N19

Crusher Drive Bearing 1
Temperature

80019895

01.001650

Tonasa	NL Generic (Single-AI)	NL Generic (Single-AI)	-	4/28/2011 10:33:45 AM	12/22/2011 12:53:23 PM	Customer	A1
--------	------------------------	------------------------	---	-----------------------	------------------------	----------	----

520LG01A02

523JB01A

	Address	Position	Term:
+24 VDC		X05.04.A	04+
Temperature	523CR01N20T01	AI N02.02..05.08	X05.04.A 04

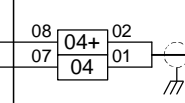

523CR01N20C01

Customer Supply

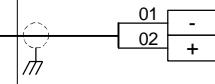

This model needs detailed information from Client on terminals to be connected.

Terminals considered now are tentative

Range 0 - 150 °C

523CR01N20
Temperature



523CR01N20

Crusher Drive Bearing 2
Temperature

80019895

01.001660

520LG01A02

523JB01A

	Address	Position	Term:
+24 VDC		X05.04.A	11+
Winding Temp. -U	523CR01N21T01	AI	N02.02..06.06 X05.04.A 11
+24 VDC		X05.04.A	12+
Winding Temp. -V	523CR01N22T01	AI	N02.02..06.08 X05.04.A 12
+24 VDC		X05.04.A	13+
Winding Temp. -W	523CR01N23T01	AI	N02.02..06.12 X05.04.A 13

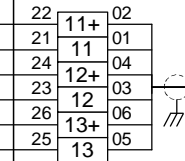

523CR01N21C01

Customer

Supply

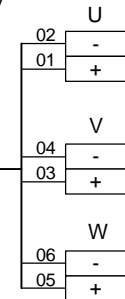

This model needs detailed information from Client on terminals to be connected.

Terminals considered now are tentative

Range: 0 - 150 °C

523CR01N21
Temperature

520LG01A02

523JB01A

	Address	Position	Term:
+24 VDC		X05.04.A	14+
Winding Temp. -U	523CR01N24T01	AI N02.02..06.14	X05.04.A 14
+24 VDC		X05.04.A	15+
Winding Temp. -V	523CR01N25T01	AI N02.02..06.16	X05.04.A 15
+24 VDC		X05.04.A	16+
Winding Temp. -W	523CR01N26T01	AI N02.02..06.18	X05.04.A 16

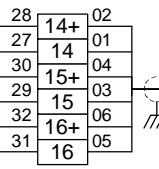

523CR01N24C01

Customer

Supply

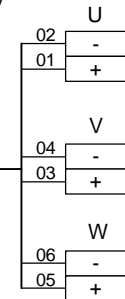

This model needs detailed information from Client on terminals to be connected.

Terminals considered now are tentative

Range: 0 - 150 °C

523CR01N24
Temperature

Tonasa	NL Generic (Single-AI)	NL Generic (Single-AI)	ARDN-IN	4/28/2011 10:34:12 AM	12/27/2011 11:41:15 AM	Customer	A1
--------	------------------------	------------------------	---------	-----------------------	------------------------	----------	----

520LG01A02

523JB01A

	Address	Position	Term:
+24 VDC		X05.04.A	08+
Temperature	523CR01N27T01	AI N02.02..05.18	X05.04.A 08

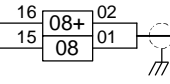

523CR01N27C01

Customer
Supply

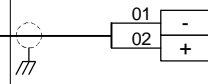

This model needs detailed information from Client on terminals to be connected.

Terminals considered now are tentative

Range 0 - 150 °C

523CR01N27
Temperature



523CR01N27

Crusher Drive Bearing 1
Temperature

80019895

01.001690

520LG01A02

523JB01A

	Address	Position	Term:
+24 VDC		X05.04.A	09+
Temperature	523CR01N28T01	AI N02.02..06.02	X05.04.A 09

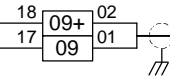

523CR01N28C01

Customer Supply

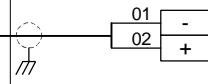

This model needs detailed information from Client on terminals to be connected.

Terminals considered now are tentative

Range 0 - 150 °C

523CR01N28
Temperature



523CR01N28

Crusher Drive Bearing 2
Temperature

80019895

01.001700

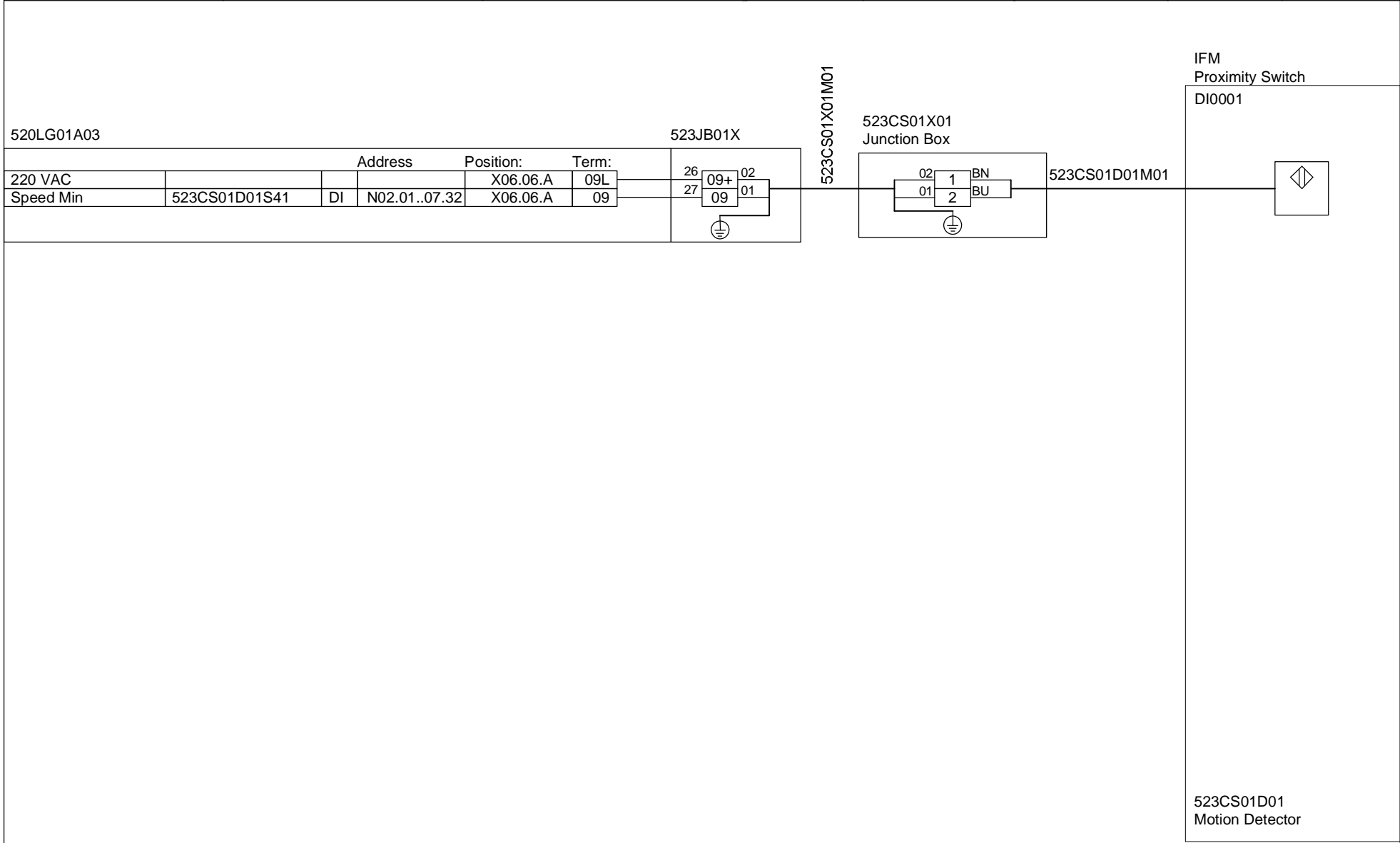

LVDB 582ER52AMC03

523CS01S01
Start/Stop/E-stop

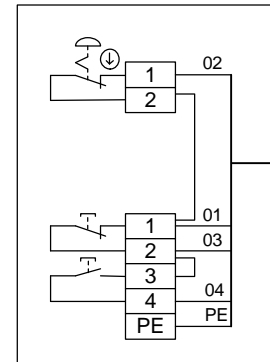

523CS01S01M01

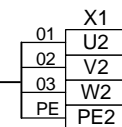
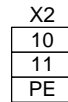
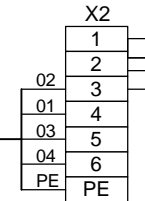

523CS01M01W01

No of cables 1

523CS01M01
Motor
3 kW (Derated)
3 kW

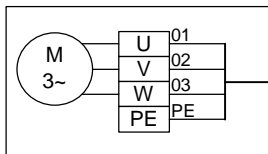

MCC Position:
Unit Type: B01 - NO
Net: 520LG01:DP4
Node: MCC/MDB 1.019
523CS01Q01
Motor Starter



523CS01M01

Spillage Conveyor
Motor

80019895

01.001720

520LG01A02

	Address	Position	Term:
0/24 VDC		X05.05.A	02-01
Level	523HP01N01L01	AI N02.02..08.04	X05.05.A 02

Endress & Hauser
Level Transmitter
FMU90+FDU93

523HP01N01C01

01	4
02	5

523HP01B01
Level
FDU-93

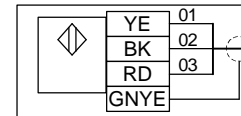

523HP01B01C01

01	9
02	10
03	11
	PE2

LVDB 582ER52AMC03

11L	02
11N	01
11PE	PE

MCC Position:
Unit Type: B42
582ER52AMC03F01 Feeder

523HP01N01M01

02	1
01	2
PE	PE1

523HP01N01
Level



523HP01N01

Hopper
Level

80019895

01.001730

523JB01A
Junction Box

Block		Term:	Signal:	Component:
01	X05.04.A	01	523CR01N11T01	523CR01N11
02	X05.04.A	01+	+24 VDC	523CR01N11
33	X05.04.A	01-		
03	X05.04.A	02	523CR01N12T01	523CR01N12
04	X05.04.A	02+	+24 VDC	523CR01N12
34	X05.04.A	02-		
05	X05.04.A	03	523CR01N19T01	523CR01N19
06	X05.04.A	03+	+24 VDC	523CR01N19
35	X05.04.A	03-		
07	X05.04.A	04	523CR01N20T01	523CR01N20
08	X05.04.A	04+	+24 VDC	523CR01N20
36	X05.04.A	04-		
09	X05.04.A	05	523CR01N14T01	523CR01N14
10	X05.04.A	05+	+24 VDC	523CR01N14
37	X05.04.A	05-		
11	X05.04.A	06	523CR01N15T01	523CR01N15
12	X05.04.A	06+	+24 VDC	523CR01N15
38	X05.04.A	06-		
13	X05.04.A	07	523CR01N16T01	523CR01N16
14	X05.04.A	07+	+24 VDC	523CR01N16
39	X05.04.A	07-		
15	X05.04.A	08	523CR01N27T01	523CR01N27
16	X05.04.A	08+	+24 VDC	523CR01N27
40	X05.04.A	08-		
17	X05.04.A	09	523CR01N28T01	523CR01N28
18	X05.04.A	09+	+24 VDC	523CR01N28
41	X05.04.A	09-		
19	X05.04.A	10	523CR01N18T01	523CR01N18
20	X05.04.A	10+	+24 VDC	523CR01N18
42	X05.04.A	10-		
21	X05.04.A	11	523CR01N21T01	523CR01N21
22	X05.04.A	11+	+24 VDC	523CR01N21
43	X05.04.A	11-		
23	X05.04.A	12	523CR01N22T01	523CR01N22
24	X05.04.A	12+	+24 VDC	523CR01N22
44	X05.04.A	12-		
25	X05.04.A	13	523CR01N23T01	523CR01N23
26	X05.04.A	13+	+24 VDC	523CR01N23
45	X05.04.A	13-		
27	X05.04.A	14	523CR01N24T01	523CR01N24
28	X05.04.A	14+	+24 VDC	523CR01N24
46	X05.04.A	14-		
29	X05.04.A	15	523CR01N25T01	523CR01N25
30	X05.04.A	15+	+24 VDC	523CR01N25
47	X05.04.A	15-		
31	X05.04.A	16	523CR01N26T01	523CR01N26
32	X05.04.A	16+	+24 VDC	523CR01N26
48	X05.04.A	16-		

49		17	.	.
50		17-	.	.
51		18	.	.
52		18-	.	.
53		19	.	.
54		19-	.	.
55		20	.	.
56		20-	.	.

520LG01A02
PLC IO-Cabinet ER-51

Block		Term:
01	X05.04.A	01
02	X05.04.A	01+
33	X05.04.A	01-
03	X05.04.A	02
04	X05.04.A	02+
34	X05.04.A	02-
05	X05.04.A	03
06	X05.04.A	03+
35	X05.04.A	03-
07	X05.04.A	04
08	X05.04.A	04+
36	X05.04.A	04-
09	X05.04.A	05
10	X05.04.A	05+
37	X05.04.A	05-
11	X05.04.A	06
12	X05.04.A	06+
38	X05.04.A	06-
13	X05.04.A	07
14	X05.04.A	07+
39	X05.04.A	07-
15	X05.04.A	08
16	X05.04.A	08+
40	X05.04.A	08-
17	X05.04.A	09
18	X05.04.A	09+
41	X05.04.A	09-
19	X05.04.A	10
20	X05.04.A	10+
42	X05.04.A	10-
21	X05.04.A	11
22	X05.04.A	11+
43	X05.04.A	11-
23	X05.04.A	12
24	X05.04.A	12+
44	X05.04.A	12-
25	X05.04.A	13
26	X05.04.A	13+
45	X05.04.A	13-
27	X05.04.A	14
28	X05.04.A	14+
46	X05.04.A	14-
29	X05.04.A	15
30	X05.04.A	15+
47	X05.04.A	15-
31	X05.04.A	16
32	X05.04.A	16+
48	X05.04.A	16-

49	X05.04.A	17
50	X05.04.A	17-
51	X05.04.A	18
52	X05.04.A	18-
53	X05.04.A	19
54	X05.04.A	19-
55	X05.04.A	20
56	X05.04.A	20-

523JB01AC01

Location :

523JB01X
Junction Box

A	Signal:	Component:
03	523BC02D07Z41	523BC02D07
02	220 VAC	523BC02D07
01+		
01-		
06	523BC02D07Z42	523BC02D07
05		
02+		
02-		
09	523BC02D11S41	523BC02D11
08	220 VAC	523BC02D11
03+	0/220 VAC	523BC02D11
07		
03-	523BC02D12Z41	523BC02X01
12		
04	220 VAC	523BC02X01
11		
04+		
10		
04-		
15	523BC02D13Z41	523BC02X02
14	220 VAC	523BC02X02
05+		
13		
05-		
18	523BC02D14T41	523BC02D14
17	220 VAC	523BC02D14
16		
06-		
21	523BC02D15Z41	523BC02D15
20	220 VAC	523BC02D15
07+		
19		
07-		
24	523AF01D01S41	523AF01D01
23	220 VAC	523AF01D01
08+		
22		
08-		
27	523CS01D01S41	523CS01X01
26	220 VAC	523CS01X01
09+		
25		
09-		
30	523BC01D03Z41	523BC01D03
29	220 VAC	523BC01D03
10+		
28		
10-		
33	523BC01D03Z42	523BC01D03
32		
11+		
31		
11-		
36	523BC01D07S41	523BC01X01
35	220 VAC	523BC01X01
12+		
34		
12-		
39	523CR01D01S41	523CR01D01
38	220 VAC	523CR01D01
13+		
37		
13-		
42	523CR01D02S41	523CR01D02
41	220 VAC	523CR01D02
14+		
40		
14-		
45	523CR01D03T41	523CR01D03
44	220 VAC	523CR01D03
15+		
43		
15-		
48	523CR01D04T41	523CR01D04
47	220 VAC	523CR01D04
16+		
46		
16-		

⊕

49		
17		
50		
17-		
51		
18		
52		
18-		
53		
19		
54		
19-		
55		
20		
56		
20-		
57		
21		
58		
21-		
59		
22		
60		
22-		
61		
23		
62		
23-		
63		
24		
64		
24-		

523JB01XM01

520LG01A03
PLC IO-Cabinet ER-51

Block	Term:	03
X06.06.A	01	03
X06.06.A	01L	01
X06.06.A	01N	01
X06.06.A	02	06
X06.06.A	02L	05
X06.06.A	02N	04
X06.06.A	03	09
X06.06.A	03L	08
X06.06.A	03N	07
X06.06.A	04	12
X06.06.A	04L	11
X06.06.A	04N	10
X06.06.A	05	15
X06.06.A	05L	14
X06.06.A	05N	13
X06.06.A	06	18
X06.06.A	06L	17
X06.06.A	06N	16
X06.06.A	07	21
X06.06.A	07L	20
X06.06.A	07N	19
X06.06.A	08	24
X06.06.A	08L	23
X06.06.A	08N	22
X06.06.A	09	27
X06.06.A	09L	26
X06.06.A	09N	25
X06.06.A	10	30
X06.06.A	10L	29
X06.06.A	10N	28
X06.06.A	11	33
X06.06.A	11L	32
X06.06.A	11N	31
X06.06.A	12	36
X06.06.A	12L	35
X06.06.A	12N	34
X06.06.A	13	39
X06.06.A	13L	38
X06.06.A	13N	37
X06.06.A	14	42
X06.06.A	14L	41
X06.06.A	14N	40
X06.06.A	15	45
X06.06.A	15L	44
X06.06.A	15N	43
X06.06.A	16	48
X06.06.A	16L	47
X06.06.A	16N	46

⊕

49		
17		
50		
17N		
51		
18		
52		
18N		
53		
19		
54		
19N		
55		
20		
56		
20N		
57		
21		
58		
21N		
59		
22		
60		
22N		
61		
23		
62		
23N		
63		
24		
64		
24N		

Location :



523JB01X

Digital
Junction Box

80019895

01.001750

Tonasa	Q B28 Hoist/Crane	Q B28 Hoist/Crane	-	11/24/2010 4:54:50 AM	12/22/2011 12:53:28 PM	Customer	A1
--------	-------------------	-------------------	---	-----------------------	------------------------	----------	----

Customer
Supply

LVDB 582ER52AMC03

X1	
U2	02
V2	03
W2	04
N2	01
PE2	PE

MCC Position:
Unit Type: B28
523SJ01Q01 Feeder

523SJ01Q01W01

No of cables 1

	X1
02	U2
03	V2
04	W2
01	N2
PE	PE2

523SJ01A01
Cabinet



523SJ01A01

Sump Pump
Cabinet

80019895

01.001760

Tonasa	DL Generic (Single-DI)	DL Generic (Single-DI)	-	4/29/2011 1:19:28 PM	12/22/2011 12:53:29 PM	Customer	A1
--------	------------------------	------------------------	---	----------------------	------------------------	----------	----

520LG01A03

	Address	Position	Term:
220 VAC		X06.07.A	04L
Level Switch	523SJ01D01L41	X06.07.A	04

523SJ01D01M01

Customer
Supply

02	1
01	2
PE	PE

This drawing needs detailed information from Client on terminals to be connected.

Terminals considered now are tentative

523SJ01D01
Switch

	523SJ01D01	Sump Pump Level Switch	80019895	01.001770
--	------------	------------------------	----------	-----------

Tonasa	Schade 523TR01/528TR01	Schade Tripper 523TR01/528TR01	-	11/24/2010 5:02:55 AM	12/22/2011 12:53:29 PM	Customer	A1
--------	------------------------	--------------------------------	---	-----------------------	------------------------	----------	----

Schade
Tripper

LVDB 582ER52AMC03

X1	
1	01
3	02
5	03
PE	PE

MCC Position:
Unit Type: B28
523TR01Q01 Feeder

523TR01Q01W01

No of cables 1

X	
01	L1
02	L2
03	L3
PE	PE

523TR01A01
Control Panel



523TR01A01

Tripper
Control Panel

80019895

01.001780

520LG01A03

	Address	Position:	Term:	
220 VAC		X06.08.A	06L	02
Common Fault	582ER51BAT110A01U41	DI	N02.01..08.29	X06.08.A 08
Undervoltage	582ER51BAT110A01U42	DI	N02.01..08.27	X06.08.A 06
Earth Fault	582ER51BAT110A01U43	DI	N02.01..08.28	X06.08.A 07



Customer Supply

582ER51BAT110A01M01

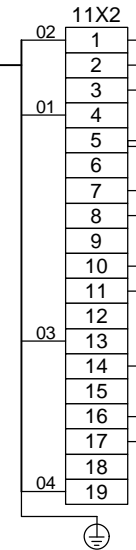

This model needs detailed information from Client on terminals to be connected.
Terminals considered now are tentative

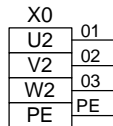

MCC/MDB position
Unit Conn. Type B32
582ER51BAT110Q01 Feeder

582ER51BAT110Q01W01

No of cables 1

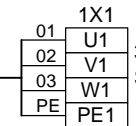

380V AC Supply

582ER51BAT110A01 Cabinet



582ER51BAT110A01 110V DC Distribution Cabinet

80019895

01.001790

Tonasa	A UPS 110V DC	110V DC (2 10A) 2	VCI-IN	4/29/2011 6:40:23 AM	12/29/2011 9:11:58 AM	Customer	A1
--------	---------------	-------------------	--------	----------------------	-----------------------	----------	----

List of Consumers	Description	Document	Doc. Page
F01 (6A)	.	.	.
F02 (6A)	.	.	.

List of Consumers	Description	Document	Doc. Page
F11 (10A) 582ER51Q02	Incoming from 582ER52A Power Feeder	80019895	01.002030
F12 (10A) 582ER52AQ02	Incoming from 581SS51 Power Feeder	80019896	01.004960

	582ER51BAT110A01	110V DC Distribution Cabinet	80019895	01.001800
--	------------------	------------------------------	----------	-----------

Tonasa	DL Generic (Single-DI)	DL Generic (Single-DI)	ARDN-IN	4/29/2011 1:07:59 PM	12/27/2011 11:56:34 AM	Customer	A1
--------	------------------------	------------------------	---------	----------------------	------------------------	----------	----

520LG01A03

	Address	Position	Term:
220 VAC		X06.08.A	16L
Electrical Room Temp (51)	582ER51D01X41	X06.08.A	16

582ER51D01M01

Customer
Supply

02	1
01	2
PE	PE

This drawing needs detailed information from Client on terminals to be connected.

Terminals considered now are tentative

582ER51D01
Switch



520LG01A03					
	Address	Position	Term:	02	
220 VAC		X06.08.A	15L	01	
Temperature High	582ER51D02T41	DI	N02.01..08.38	X06.08.A	15
					⊕

582ER51D02M01

02	1
01	2
PE	PE

This drawing needs detailed information from Client on terminals to be connected.

Terminals considered now are tentative

582ER51D02
Switch

Customer

Supply

582ER51LD01Q01
Feeder

582ER51LD01Q01W01

Doc: 80019895
Page: 01.001840

No of cables 22

02	U1
03	V1
04	W1
01	N1
PE	PE1

582ER51LD01A01
Cabinet



582ER51LD01A01 Lighting Transformer
Cabinet

80019895

01.001830

LVDB 582ER51LV01

582ER51LV01Q21
Feeder

582ER51LD01Q01Y01

Document: 80019895
Page: 01.001880

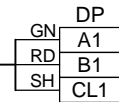

582ER51PD01Q01
Feeder

582ER51PD01Q01Y01

Document: 80019895
Page: 01.002020

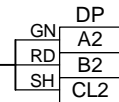

582ER51LD01A01
Cabinet

582ER51LD01Q01W01

Doc: 80019895
Page: 01.001830

No of cables 2

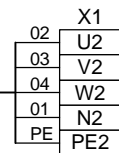

MCC/MDB position
Unit Conn. Type B29

582ER51LD01Q01 Feeder



582ER51LD01Q01 Lighting Transformer
Feeder

80019895

01.001840

520LG01A03

LVDB 582ER51LV01

Address	Position:	Term:
220 VAC	X06.07.A	01L
Power Supply OK	582ER51LV01F01E41	DI N02.01..08.02 X06.07.A

582ER51LV01F01M01

X2	
02	1
01	2
PE	3

List of consumers

Description	Purpose	Document	Page
F1 (2A)	.	.	.
F2 (2A)	.	.	.
F3 (2A)	.	.	.
F4 (2A)	.	.	.
F5 (2A)	.	.	.
F6 (2A)	.	.	.
F7 (2A)	.	.	.
F8 (2A)	.	.	.
F9 (2A)	.	.	.
F10 (2A)	.	.	.
F11 (4A)	.	.	.
F12 (4A)	.	.	.
F13 (4A)	.	.	.
F14 (4A)	.	.	.
F15 (4A)	.	.	.
F16 (4A)	.	.	.
F17 (4A)	.	.	.
F18 (4A)	.	.	.
F19 (6A)	.	.	.
F20 (6A)	.	.	.
F21(16A) 582ER51LV01Q02	Incoming from 582ER51	Feeder	80019895 01.001870
F22(16A)	.	.	.

MCC Position
Unit Conn. Type B42

582ER51LV01F01 Feeder



582ER51LV01F01 Control Voltage Feeder

80019895

01.001850

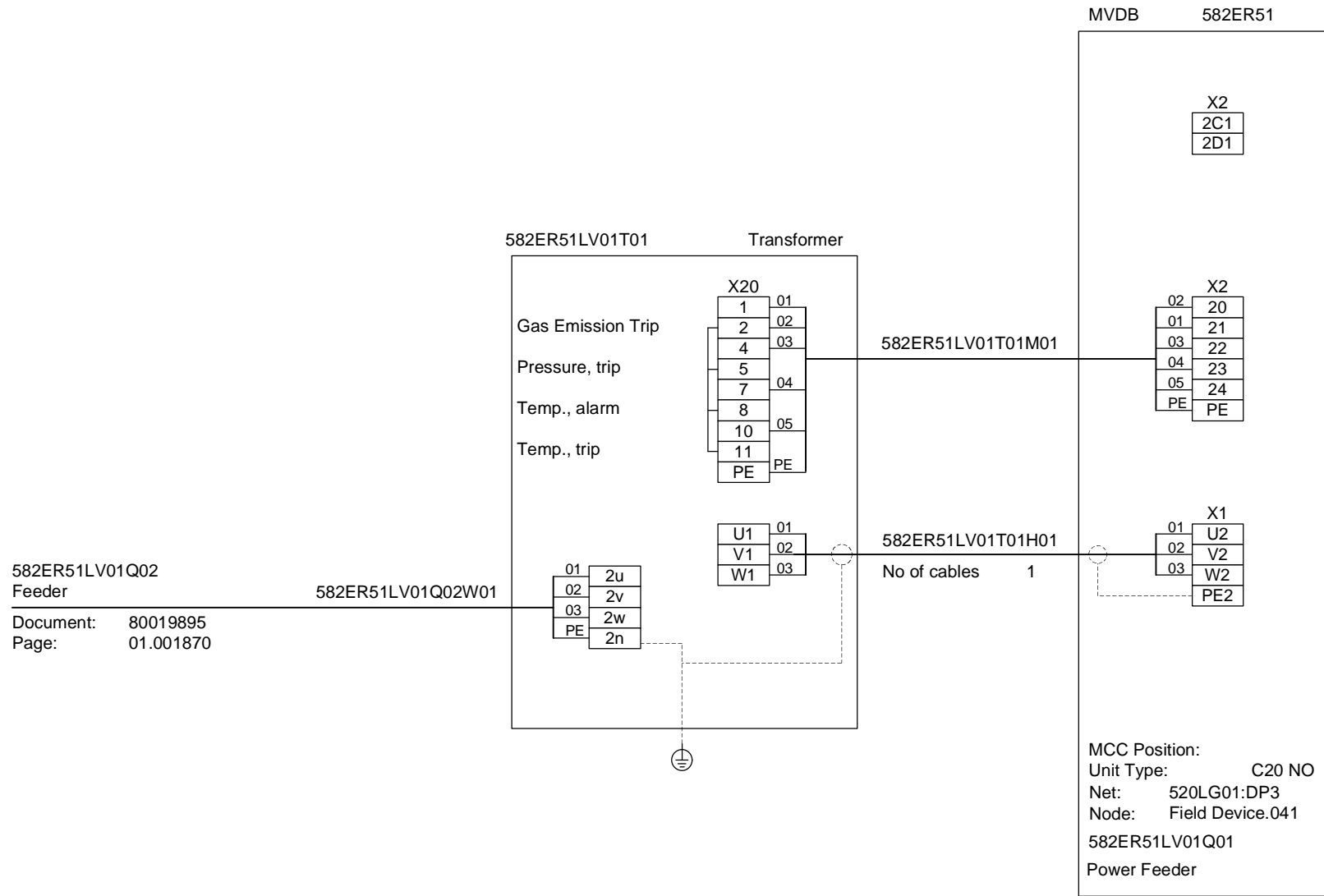

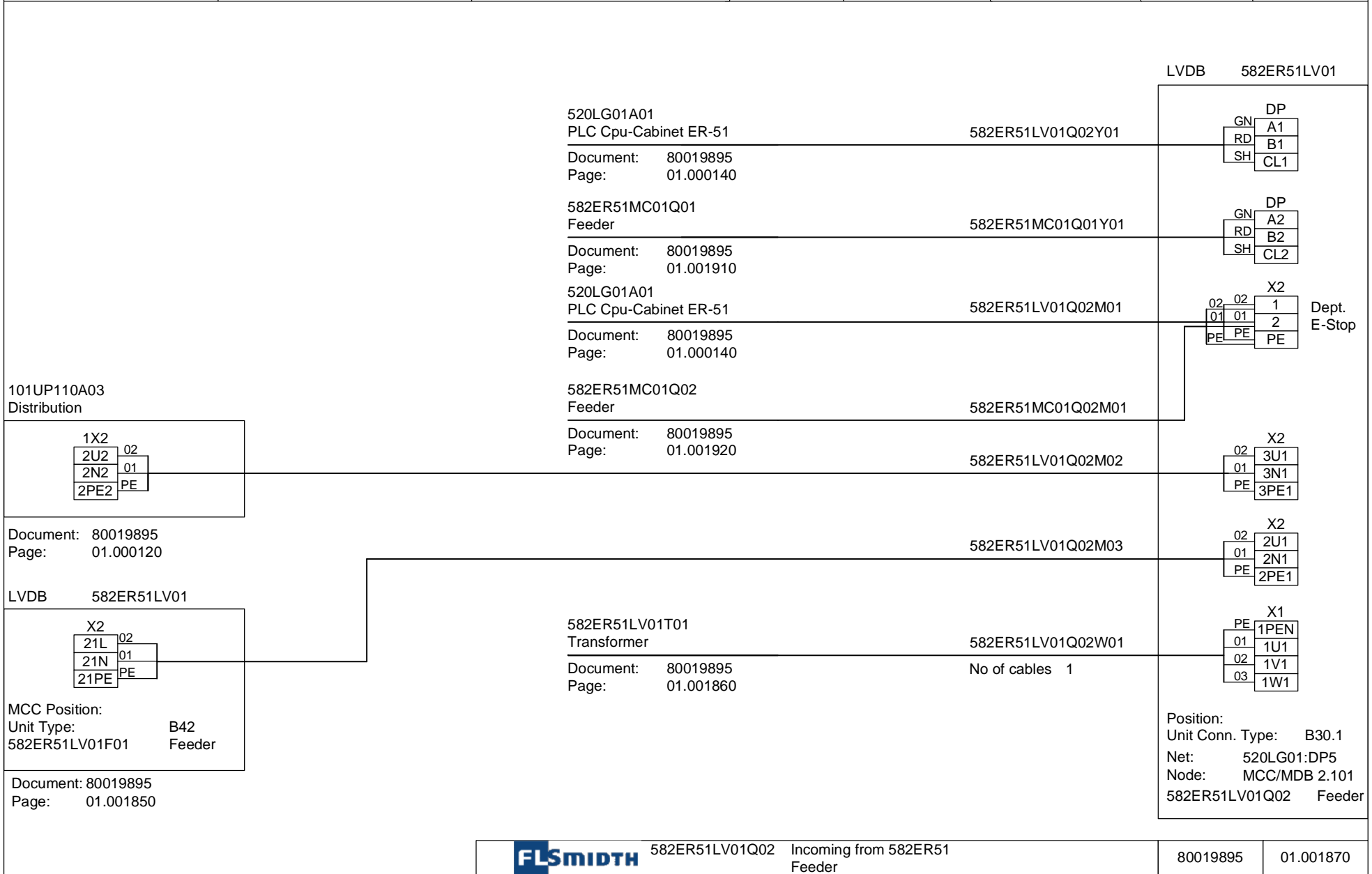

582ER51LV01Q02 Incoming from 582ER51 Feeder

80019895 01.001870

LVDB 582ER51LV01

582ER51MC01Q01
Feeder

582ER51LV01Q21Y01

Document: 80019895
Page: 01.001910

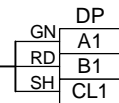

582ER51LD01Q01
Feeder

582ER51LD01Q01Y01

Document: 80019895
Page: 01.001840

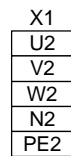
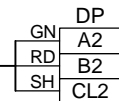

MCC/MDb position
Unit Conn. Type B29
Net: 520LG01:DP5
Node: MCC/MDb 2.103
582ER51LV01Q21
Feeder



582ER51LV01Q21 MCC Spare
Feeder

80019895

01.001880

520LG01A03

LVDB 582ER51MC01

Address	Position:	Term:
220 VAC	X06.07.A	02L
Power Supply OK	582ER51MC01F01E41	DI N02.01..08.03 X06.07.A

582ER51MC01F01M01

X2	
02	1
01	2
PE	3

List of consumers

Description	Purpose	Document	Page
F1 (2A) 521BW01A01 Belt Weigher	Control Panel	80019895	01.000710
F2 (2A)
F3 (2A)
F4 (2A) 521BF01X01 Bag Filter	Junction Box	80019895	01.000700
F5 (2A) 521CR01LX1 Lighting	Slip Ring Light	80019895	01.000810
F6 (2A) 521CR01LX2 Lighting	Slip Ring Light	80019895	01.000820
F7 (2A)
F8 (2A)
F9 (2A)
F10 (2A)
F11 (4A) 521CR01R01 Crusher	Rotor Starter	80019895	01.000990
F12 (4A) 521CR01R02 Crusher	Rotor Starter	80019895	01.001010
F13 (4A) 521HP01N01 Hopper	Level	80019895	01.001160
F14 (4A)
F15 (4A)
F16 (4A)
F17 (4A)
F18 (4A)
F19 (6A) 521AF01U01 Apron Feeder	Frequency Converter	80019895	01.000260
F20 (6A)
F21(16A) 582ER51MC01Q02 Incoming from 582Er51LV01	Feeder	80019895	01.001920
F22(16A)

MCC Position
Unit Conn. Type B42

582ER51MC01F01 Feeder



582ER51MC01F01 Control Voltage Feeder

80019895

01.001890

520LG01A03

LVDB 582ER51MC01

Address	Position:	Term:
220 VAC	X06.07.A	03L
Power Supply OK	582ER51MC01F02E41	DI N02.01..08.04 X06.07.A

582ER51MC01F02M01

X2	
02	1
01	2
PE	3

List of consumers

Description	Purpose	Document	Page
F1 (2A)
F2 (2A)
F3 (2A)
F4 (2A)
F5 (2A)
F6 (2A)
F7 (2A)
F8 (2A)
F9 (2A)
F10 (2A)
F11 (4A)
F12 (4A)
F13 (4A)
F14 (4A)
F15 (4A)
F16 (4A)
F17 (4A)
F18 (4A)
F19 (6A)
F20 (6A)
F21(16A)
F22(16A)

MCC Position
Unit Conn. Type B42

582ER51MC01F02 Feeder



582ER51MC01F02 Control Voltage Feeder

80019895

01.001900

LVDB 582ER51LV01

582ER51LV01Q02
Feeder

582ER51MC01Q01Y01

Document: 80019895
Page: 01.001870

GN	DP
RD	A1
SH	B1
	CL1

582ER51LV01Q21
Feeder

582ER51LV01Q21Y01

Document: 80019895
Page: 01.001880

GN	DP
RD	A2
SH	B2
	CL2

582ER51MC01Q02
Feeder

582ER51MC01Q01W01

Document: 80019895
Page: 01.001920

No of cables 1

	X1
02	U2
03	V2
04	W2
01	N2
PE	PE2

MCC/MDB position
Unit Conn. Type B29

582ER51MC01Q01
Feeder



582ER51MC01Q01 MCC
Feeder

80019895

01.001910

LVDB 582ER51MC01

582ER51LV01Q02
Feeder 582ER51MC01Q02M01

Document: 80019895
Page: 01.001870

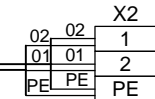

Dept.
E-Stop

582ER52AMC03Q02
Feeder 582ER52AMC03Q02M01

Document: 80019895
Page: 01.002070

101UP110A03
Distribution

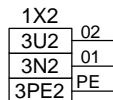

582ER51MC01Q02M02

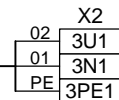

UPS

Document: 80019895
Page: 01.000120

582ER51MC01Q02M03

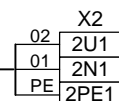

220 VAC

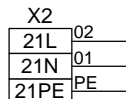

582ER51MC01Q01
Feeder 582ER51MC01Q01W01

Doc: 80019895
Page: 01.001910

No of cables 1

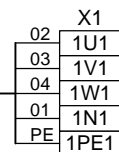

MCC Position
Unit Conn. Type B42
582ER51MC01F01 Feeder

Position:
Unit Conn. Type: B30.2

582ER51MC01Q02
Feeder



582ER51MC01Q02 Incoming from 582Er51LV01
Feeder

80019895

01.001920

LVDB 582ER51MC01

582ER51PD01Q01
Feeder

582ER51MC01Q02Y01

Document: 80019895
Page: 01.002020

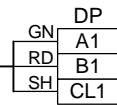

Position:
Unit Conn. Type: B30.2

582ER51MC01Q02
Feeder



582ER51MC01Q02 Incoming from 582Er51LV01
Feeder

80019895

01.001930

Tonasa	Q B28 Spare	Q B28 Spare	-	11/29/2010 5:57:36 AM	12/22/2011 12:53:37 PM	Customer	A1
--------	-------------	-------------	---	-----------------------	------------------------	----------	----

LVDB 582ER51MC01

X1
 U2
 V2
 W2
 N2
 PE2

MCC/MDB position
 Unit Conn. Type B28

582ER51MC01Q21
 Feeder

	582ER51MC01Q21 Spare Feeder	80019895	01.001940
--	-----------------------------	----------	-----------

Tonasa	Q B28 Spare	Q B28 Spare	-	11/29/2010 5:58:37 AM	12/22/2011 12:53:38 PM	Customer	A1
--------	-------------	-------------	---	-----------------------	------------------------	----------	----

LVDB 582ER51MC01

X1
 U2
 V2
 W2
 N2
 PE2

MCC/MDB position
 Unit Conn. Type B28

582ER51MC01Q22
 Feeder

	582ER51MC01Q22 Spare Feeder	80019895	01.001950
--	-----------------------------	----------	-----------

Tonasa	Q B28 Spare	Q B28 Spare	-	11/29/2010 5:58:58 AM	12/22/2011 12:53:39 PM	Customer	A1
--------	-------------	-------------	---	-----------------------	------------------------	----------	----

LVDB 582ER51MC01

X1
 U2
 V2
 W2
 N2
 PE2

MCC/MDB position
 Unit Conn. Type B28

582ER51MC01Q23
 Feeder

	582ER51MC01Q23 Spare Feeder	80019895	01.001960
--	-----------------------------	----------	-----------

Tonasa	Q B01-PM S	Q B01-ED S	-	11/29/2010 5:48:06 AM	12/22/2011 12:53:39 PM	Customer	A1
--------	------------	------------	---	-----------------------	------------------------	----------	----

LVDB 582ER51MC01

X2

1
2
3
4
5
6
PE

X2

10
11
PE

X4

1
2

X1

U2
V2
W2
PE2

MCC Position:
Unit Type: B01 - PM
Net: 520LG01:DP5
Node: MCC/MDB 2.036
582ER51MC01Q51
Motor Starter



582ER51MC01Q51 Spare
Motor Starter

80019895

01.001970

Tonasa	Q B01-PM S	Q B01-ED S	-	11/29/2010 5:49:23 AM	12/22/2011 12:53:40 PM	Customer	A1
--------	------------	------------	---	-----------------------	------------------------	----------	----

LVDB 582ER51MC01

X2

1
2
3
4
5
6
PE

X2

10
11
PE

X4

1
2

X1

U2
V2
W2
PE2

MCC Position:
Unit Type: B01 - PM
Net: 520LG01:DP5
Node: MCC/MDB 2.037
582ER51MC01Q52
Motor Starter



582ER51MC01Q52 Spare
Motor Starter

80019895

01.001980

Tonasa	Q B01-NO S	Q B01-NO S	-	11/29/2010 5:51:39 AM	12/22/2011 12:53:40 PM	Customer	A1
--------	------------	------------	---	-----------------------	------------------------	----------	----

LVDB 582ER51MC01

X2

1
2
3
4
5
6
PE

X2

10
11
PE

X4

1
2

X1

U2
V2
W2
PE2

MCC Position:
Unit Type: B01 - NO
Net: 520LG01:DP5
Node: MCC/MDB 2.038
582ER51MC01Q53
Motor Starter



582ER51MC01Q53 Spare
Motor Starter

80019895

01.001990

520LG01A02

	Address	Position	Term:
+24 VDC		X05.05.A	01+
Temperature	582ER51N01T01	AI N02.02..08.02	01

Customer
Supply

582ER51N01C01

02	1 (+)
01	2 (-)

This drawing needs detailed information from Client on terminals to be connected.

Terminals considered now are tentative

Range: 0 - 150 °C

582ER51N01
Temperature



582ER51N01

Electrical Room -51
Temperature

80019895

01.002000

Customer

Supply

582ER51PD01Q01
Feeder

582ER51PD01Q01W01

Doc: 80019895
Page: 01.002020

No of cables 22

02	U1
03	V1
04	W1
01	N1
PE	PE1

582ER51PD01A01
Cabinet



582ER51PD01A01 Distribution Transformer
Cabinet

80019895

01.002010

LVDB 582ER51LV01

582ER51LD01Q01
Feeder

582ER51PD01Q01Y01

Document: 80019895
Page: 01.001840

GN	DP
RD	A1
SH	B1
	CL1

582ER51MC01Q02
Feeder

582ER51MC01Q02Y01

Document: 80019895
Page: 01.001920

GN	DP
RD	A2
SH	B2
	CL2

582ER51PD01A01
Cabinet

582ER51PD01Q01W01

Doc: 80019895
Page: 01.002010

No of cables 2

	X1
02	U2
03	V2
04	W2
01	N2
PE	PE2

MCC/MDB position
Unit Conn. Type B29

582ER51PD01Q01
Feeder



582ER51PD01Q01 Distribution Transformer
Feeder

80019895

01.002020

MVDB 582ER51

520LG01A01
PLC Cpu-Cabinet ER-51 582ER51Q02Y01

Document: 80019895
Page: 01.000140

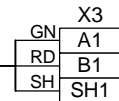

582ER51LV01Q01
Power Feeder 582ER51LV01Q01Y01

Document: 80019895
Page: 01.001860

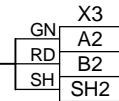

520LG01A01
PLC Cpu-Cabinet ER-51 582ER51Q02M01

Document: 80019895
Page: 01.000140

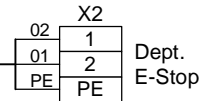

MCC Position:
Unit Type: C31 ES
Net: 520LG01:DP3
Node: Field Device.040
582ER51Q02
Power Feeder



582ER51Q02 Incoming from 582ER52A
Power Feeder

80019895

01.002030

MVDB 582ER51

101UP110A03
Distribution

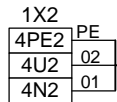

582ER51BAT110A01
Cabinet

582ER51Q02W01

Document: 80019895
Page: 01.001790

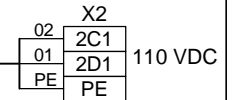

582ER51Q02M02

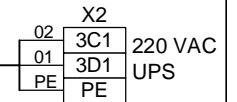

Document: 80019895
Page: 01.000100

582ER51Q01
Power Feeder

582ER51Q02H01

Document: 80019896
Page: 01.004530

No of cables 1

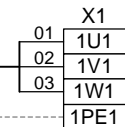

MCC Position:
Unit Type: C31 ES
Net: 520LG01:DP3
Node: Field Device.040
582ER51Q02
Power Feeder



582ER51Q02

Incoming from 582ER52A
Power Feeder

80019895

01.002040

520LG01A03

LVDB 582ER52AMC03

		Address	Position:	Term:
220 VAC			X06.07.A	06L
Power Supply OK	582ER52AMC03F01E41	DI	N02.01..08.07	06

582ER52AMC03F01M01

	X2
02	1
01	2
PE	3

List of consumers

	Description	Purpose	Document	Page
F1 (2A)
F2 (2A)	523CR01D01	Crusher	80019895	01.001510
F3 (2A)	523CR01D02	Crusher	80019895	01.001520
F4 (2A)	523CR01D03	Crusher Coupling Drv.-1	80019895	01.001530
F5 (2A)	523CR01D04	Crusher Coupling Drv.-2	80019895	01.001540
F6 (2A)
F7 (2A)
F8 (2A)
F9 (2A)
F10 (2A)
F11 (4A)	523HP01N01	Hopper	80019895	01.001730
F12 (4A)
F13 (4A)
F14 (4A)
F15 (4A)
F16 (4A)
F17 (4A)
F18 (4A)
F19 (6A)	523AF01U01	Apron Feeder	80019895	01.001350
F20 (6A)
F21(16A)	582ER52AMC03Q02	Incoming	80019895	01.002070
F22(16A)

MCC Position
Unit Conn. Type B42

582ER52AMC03F01 Feeder



582ER52AMC03F01 Control Voltage
Feeder

80019895

01.002050

520LG01A03

LVDB 582ER52AMC03

Address	Position:	Term:
220 VAC	X06.07.A	07L
Power Supply OK	582ER52AMC03F02E41	DI
	N02.01..08.08	X06.07.A

582ER52AMC03F02M01

X2	
02	1
01	2
PE	3



List of consumers

Description	Purpose	Document	Page
F1 (2A)
F2 (2A)
F3 (2A)
F4 (2A)
F5 (2A)
F6 (2A)
F7 (2A)
F8 (2A)
F9 (2A)
F10 (2A)
F11 (4A)
F12 (4A)
F13 (4A)
F14 (4A)
F15 (4A)
F16 (4A)
F17 (4A)
F18 (4A)
F19 (6A)
F20 (6A)
F21(16A)
F22(16A)

MCC Position
Unit Conn. Type B42

582ER52AMC03F02 Feeder



582ER52AMC03F02 Control Voltage Feeder

80019895

01.002060

LVDB 582ER52AMC03

582ER51MC01Q02
Feeder
Document: 80019895
Page: 01.001920

582ER52AMC03Q02M01

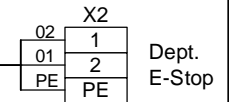

101UP110A03
Distribution

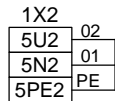

582ER52AMC03Q02M02

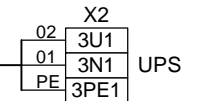

Document: 80019895
Page: 01.000120

582ER52AMC03Q02M03

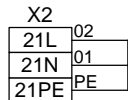
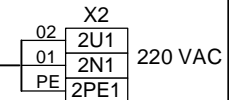

582ER52AMC03Q01
Feeder
Document: 80019896
Page: 01.004820

582ER52AMC03Q01W01

No of cables 11

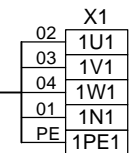

MCC Position
Unit Conn. Type B42
582ER52AMC03F01 Feeder

Position:
Unit Conn. Type: B30.2

582ER52AMC03Q02
Feeder



582ER52AMC03Q02 Incoming
Feeder

80019895

01.002070

LVDB 582ER52AMC03

520LG01A12
 Network Interface Box Profibus

582ER52AMC03Q02Y01

Document: 80019895
 Page: 01.000180

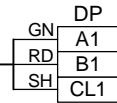

Position:
 Unit Conn. Type: B30.2

582ER52AMC03Q02
 Feeder



582ER52AMC03Q02 Incoming
 Feeder

80019895

01.002080

Tonasa	Q B28 Spare	Q B28 Spare	-	11/29/2010 10:24:46 AM	12/22/2011 12:53:45 PM	Customer	A1
--------	-------------	-------------	---	------------------------	------------------------	----------	----

LVDB 582ER52AMC03

X1
 U2
 V2
 W2
 N2
 PE2

MCC/MDB position
 Unit Conn. Type B28

582ER52AMC03Q21
 Feeder

	582ER52AMC03Q21 Spare Feeder	80019895	01.002090
--	---------------------------------	----------	-----------

Tonasa	Q B28 Spare	Q B28 Spare	-	11/29/2010 10:25:12 AM	12/22/2011 12:53:46 PM	Customer	A1
--------	-------------	-------------	---	------------------------	------------------------	----------	----

LVDB 582ER52AMC03

X1
 U2
 V2
 W2
 N2
 PE2

MCC/MDB position
 Unit Conn. Type B28

582ER52AMC03Q22
 Feeder

	582ER52AMC03Q22 Spare Feeder	80019895	01.002100
--	---------------------------------	----------	-----------

Tonasa	Q B01-PM S	Q B01-ED S	-	11/29/2010 10:21:38 AM	12/22/2011 12:53:46 PM	Customer	A1
--------	------------	------------	---	------------------------	------------------------	----------	----

LVDB 582ER52AMC03

X2

1
2
3
4
5
6
PE

X2

10
11
PE

X4

1
2

X1

U2
V2
W2
PE2

MCC Position:
Unit Type: B01 - PM
Net: 520LG01:DP4
Node: MCC/MDB 1.020
582ER52AMC03Q51
Motor Starter



582ER52AMC03Q51 Spare
Motor Starter

80019895

01.002110

Tonasa	Q B01-NO S	Q B01-NO S	-	11/29/2010 10:23:19 AM	12/22/2011 12:53:47 PM	Customer	A1
--------	------------	------------	---	------------------------	------------------------	----------	----

LVDB 582ER52AMC03

X2

1
2
3
4
5
6
PE

X2

10
11
PE

X4

1
2

X1

U2
V2
W2
PE2

MCC Position:
Unit Type: B01 - NO
Net: 520LG01:DP4
Node: MCC/MDB 1.021
582ER52AMC03Q52
Motor Starter



582ER52AMC03Q52 Spare
Motor Starter

80019895

01.002120

520LG01A03

	Address	Position:	Term:	
220 VAC		X06.08.A	09L	02
Common Fault	582ER52BAT110A01U41	DI	N02.01..08.34	X06.08.A 11
Undervoltage	582ER52BAT110A01U42	DI	N02.01..08.32	X06.08.A 09
Earth Fault	582ER52BAT110A01U43	DI	N02.01..08.33	X06.08.A 10

Customer Supply

582ER52BAT110A01M01

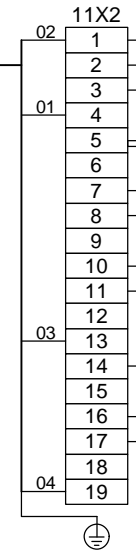

This model needs detailed information from Client on terminals to be connected.

Terminals considered now are tentative

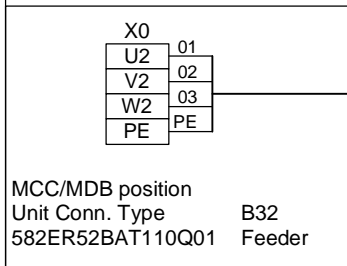

582ER52BAT110Q01W01

No of cables 1

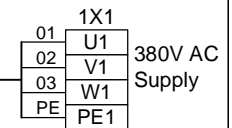

582ER52BAT110A01 Cabinet



582ER52BAT110A01 110V DC Distribution Cabinet

80019895

01.002130

Tonasa	A UPS 110V DC	110V DC (2 10A) 2	-	4/29/2011 10:22:53 AM	12/22/2011 12:53:48 PM	Customer	A1
--------	---------------	-------------------	---	-----------------------	------------------------	----------	----

List of Consumers	Description	Document	Doc. Page
F01 (6A)	.	.	.
F02 (6A)	.	.	.

List of Consumers	Description	Document	Doc. Page
F11 (10A)	.	.	.
F12 (10A)	.	.	.

520LG01A03

	Address	Position:	Term:	
220 VAC		X06.08.A	12L	02
Common Fault	582ER53BAT110A01U41	DI	N02.01..08.37	X06.08.A 14 04
Undervoltage	582ER53BAT110A01U42	DI	N02.01..08.35	X06.08.A 12 01
Earth Fault	582ER53BAT110A01U43	DI	N02.01..08.36	X06.08.A 13 03

Customer Supply

582ER53BAT110A01M01

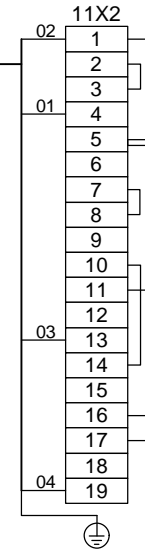

This model needs detailed information from Client on terminals to be connected.
Terminals considered now are tentative

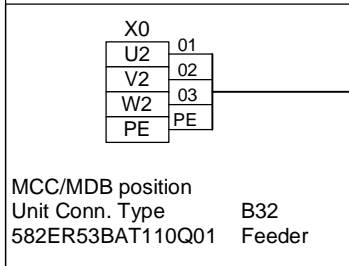

582ER53BAT110Q01W01

No of cables 1

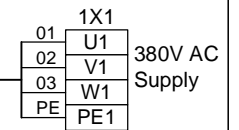

582ER53BAT110A01 Cabinet



582ER53BAT110A01 110V DC Distribution Cabinet

80019895

01.002150

List of Consumers	Description	Document	Doc. Page
F01 (6A)	.	.	.
F02 (6A)	.	.	.

List of Consumers	Description	Document	Doc. Page
F11 (10A)	.	.	.
F12 (10A)	.	.	.